

# ADVANCED R&D AND TECHNOLOGIES

## THE NAS OF UKRAINE

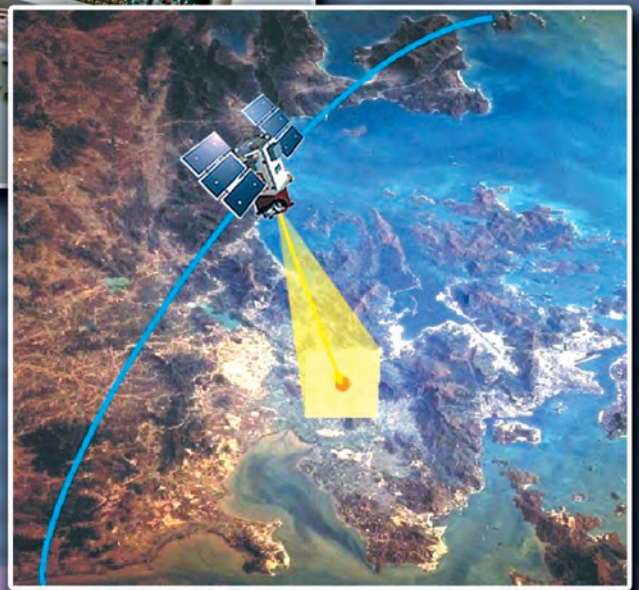

**INFORMATION  
TECHNOLOGY**

# ADVANCED R&D AND TECHNOLOGIES

## THE NAS OF UKRAINE

### **SPECIAL ISSUES**

ENVIRONMENT AND NATURE PROTECTION

FOOD INDUSTRY

FUEL, LUBRICANTS,  
AND TECHNOLOGIES

INDUSTRIAL AGRICULTURE  
AND LANDSCAPE GARDENING

INFORMATION AND SENSOR SYSTEMS  
AND DEVICES

### **INFORMATION TECHNOLOGY**

MACHINE-BUILDING  
AND INSTRUMENT ENGINEERING

MEDICAL PRODUCTS  
AND MEDICAL DEVICE ENGINEERING

POWER ENGINEERING  
AND ENERGY EFFICIENCY

TECHNOLOGIES AND EQUIPMENT  
FOR EXPLORING, ESTIMATING,  
AND EXTRACTING MINERAL RESOURCES

TECHNOLOGIES FOR CONSTRUCTION  
AND FUNCTIONAL MATERIALS

## 3D CROSSBAR SWITCHING SYSTEM WITH OPTICAL SWITCH

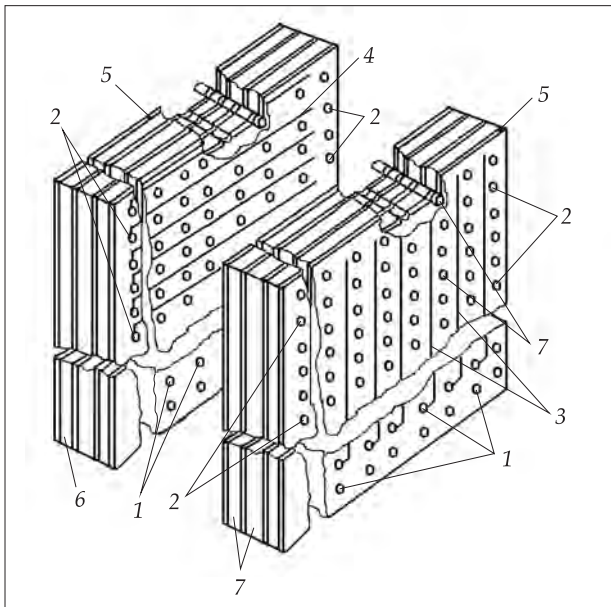

3D crossbar switching system with optical switch  
 1 – input, 2 – output, 3 – input bus, 4 – output bus,  
 5 – layers of input and output buses, 6 – dielectric,  
 7 – optic fiber with contacts

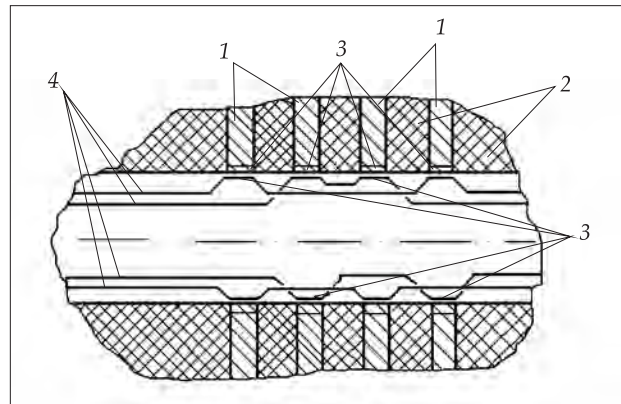

Electro-optical connector 1 – layers of input and output buses, 2 – dielectric, 3 – electro-optical contacts, 4 – optic fiber

### Areas of Application

The switch is to be used in computer systems for interblock data transfer. The product is aimed at developers of new computer equipment

### Specification

The switch is a matrix containing inputs and outputs. The area occupied is minimized due to its multilayer structure. Each layer is made of dielectric with orthogonal buses at the intersection of which there is the optical connector common to all layers, which is designed as electro-optical switch

### Advantages

The existing crossbar switches involve  $n$  out of  $n^2$  switching points for simultaneous connection. In order to minimize the number of switching points located on the surface of crossbar switch its configuration has been optimized by reducing the number of matrix rows and columns and by placing buses on parallel surfaces. As a result, the crossbar switch has a multilayer structure

### Stage of Development.

#### Suggestions for Commercialization

IRL2, TRL2

Sketch of 3D crossbar switching system configuration and computing circuit is provided upon request

### IPR Protection

IPR3

### Contact Information

Nadia K. Timofeeva, International Research and Training Center for Information Technologies and Systems of the NAS of Ukraine and the Ministry of Education and Science of Ukraine; +38 044 526 11 75, e-mail: Tymnad@gmail.com

## ALGEBRAIC PROGRAMMING SYSTEM

```

solve_lin:=rs(x,y,z,i)(
  (V i + y = z) = (V i = canpl( z+y $ (-1))),
  (V i $ x + y = z) = (V i = canpl((z+y $ (-1)) $ (1.0/x))),
  ( x + y = z) = solve_lin(y = canpl(z+(-1) * x)),
  (V i $ x = z) = (V i = canpl(z $ (1.0/x))),
  (V i = z) = (V i=z),
  ( x = x) = (x = x),
  ( x = z) = 0
);

```

Example of program in the algebraic programming system

### Areas of Application

The system is designed for organizations that produce systems for verification, testing, analysis, and transformation of programs and for developers of software applications using algebraic programming language APLAN

### Specification

The system is compatible with Linux and Windows and can operate in the online mode

### Advantages

The system has no counterparts in Ukraine. It is the fastest term rewriting system as compared with all major world competitors. The system has interfaces with all major theorem proving systems or algebraic programming systems designed for solving specific problems

### Stage of Development. Suggestions for Commercialization

IRL6, TRL4  
Commercial versions of software system and staff training are provided upon request

### IPR Protection

IPR1, IPR3

### Contact Information

*Sergii V. Yershov*, Glushkov Institute of Cybernetics of the NAS of Ukraine;  
+38 044 526 41 78, e-mail: ErshovSV@nas.gov.ua

## ALGORITHMS AND SOFTWARE FOR PARAMETRIC DETERMINATION OF GAS AEROTHERMODYNAMIC PROCESSES IN VARIOUS ENGINEERING FACILITIES

### Areas of Application

The algorithms and software are to be used for supporting the design and test setup works in rocket and space engineering, power engineering, and metallurgy

### Specification

Algorithms and software (AS) enable determining the parameters of gas thermodynamic processes considering homogeneous and heterogeneous chemical transformations, phase transitions, interactions between the working body and the bounding surface materials for solving the problems of rockets aero-gas dynamics, ramjet engines, feed systems for jet-rocket engines and micromotors, flame spraying, etc.

### Advantages

The use of AS can save time and costs for test setup works due to application of mathematical models simulating the key specific features of processes and quick adjustment for determining the parameters of specific devices

### Stage of Development. Suggestions for Commercialization

IRL4, TRL4

Algorithms and software are ready to be used for supporting the development and operation of specific engineering systems

### IPR Protection

IPR3



*a*

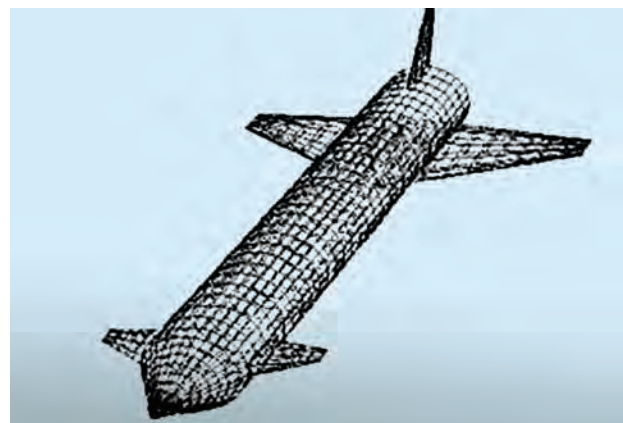

*b*

Applications of algorithms and software:  
*a* – feed systems for jet-rocket engines ;  
*b* – gas aerodynamics of rockets

### Contact Information

Valerii I. Tymoshenko, Institute of Technical Mechanics of the NAS of Ukraine and the State Space Agency of Ukraine; +38 056 372 06 41, e-mail: vitymoshenko@nas.gov.ua

# ASTRID TECHNOLOGY FOR MODELING AND FORECASTING OF COMPLEX PROCESSES AND SYSTEMS

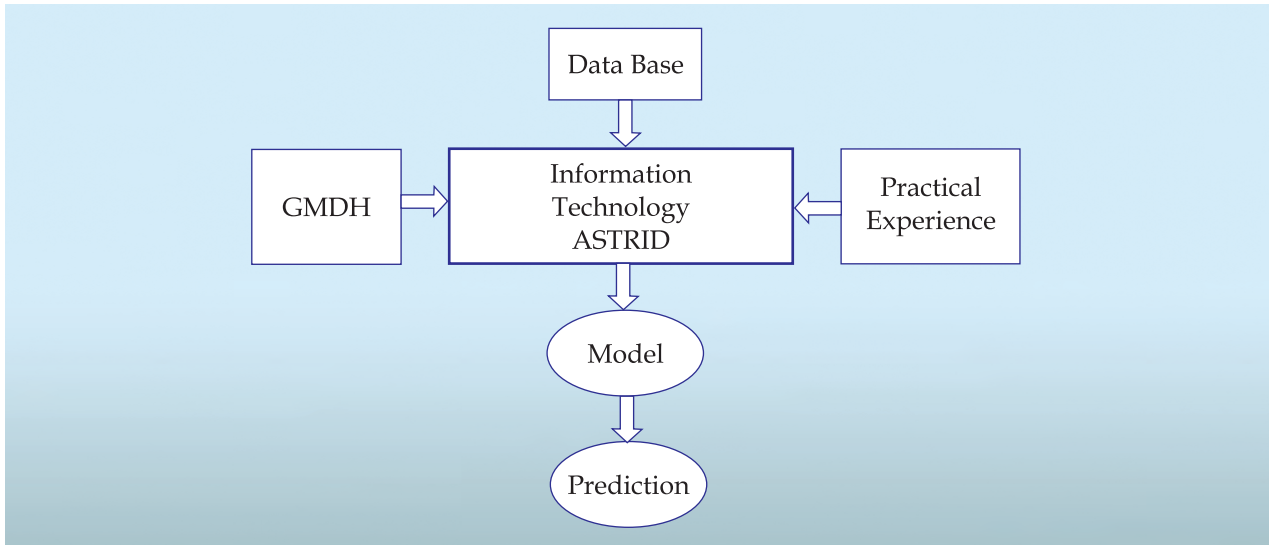

ASTRID technology general structure

## Areas of Application

The technology is to be used for automated construction of mathematical models of complex objects and processes from statistical databases under conditions of uncertainty and information incompleteness for the purpose of detection of regularities, identification, forecasting, optimization, control, and decision making

## Specification

The technology makes it possible to build linear, polynomial, autoregressive, difference (dynamic), nonlinear network models of static objects, time series, dynamic objects, and processes. It can be used both independently and as part of control systems, information-analytical and decision-making support systems

## IPR Protection

IPR1, IPR3

## Advantages

The ASTRID technology is the most effective for solving the tasks of intelligent data analysis under conditions of a priori information incompleteness, namely, for building models of economic, ecological, and technological processes and systems. Due to its originality, it will be competitive both in Ukraine and abroad

## Stage of Development. Suggestions for Commercialization

IRL6, TRL5  
Customization and the author's support

## Contact Information

*Volodymyr S. Stepashko*, International Research and Training Center for Information Technologies and Systems of the NAS and the Ministry of Education and Science of Ukraine;  
+38 067 442 56 17, e-mail: stepashko@irtc.org.ua

# AUTOMATED INFORMATION AND COMPUTATION SYSTEM FOR RATING THE PERFORMANCE OF SCHOLARLY RESEARCHERS OF R&D INSTITUTIONS

## Areas of Application

The system is to be used for monitoring the performance of scholarly researchers of various R&D institutions. It provides automated data collection, processing, and delivery upon request for scoring the researcher's rating and compliance with position occupied, as well as informational support for decision-making

## Specification

Client-server technology; server software: PHP; server database: in the relational form; based on MySQL database; user PCs are operated by the network operating system; software access: HTTP protocol; choice of browsers depending on support of scripting in JavaScript and Hypertext CSS style sheets

## Advantages

There are no counterparts, the system does not require expensive equipment, is downloaded on PC or available online; suitable for various R&D institutions; criteria and weight coefficients are adjustable

## Stage of Development. Suggestions for Commercialization

IRL8, TRL7

Installation on PC or Internet access, customization, and staff training, upon request

## Contact Information

Tatiana V. Pyatchanina, RE Kavetsky Institute of Experimental Pathology, Oncology, and Radiobiology of the NAS of Ukraine; +38 044 259 01 67, e-mail: tanya\_pyatchanina@ukr.net

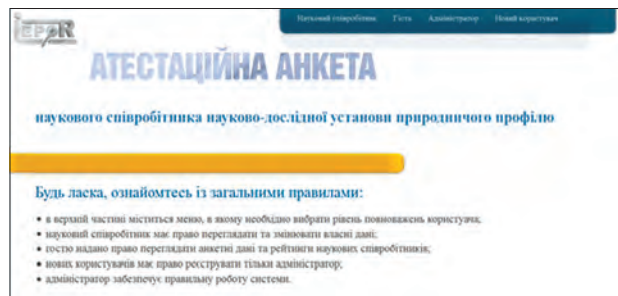

Home page of automated system

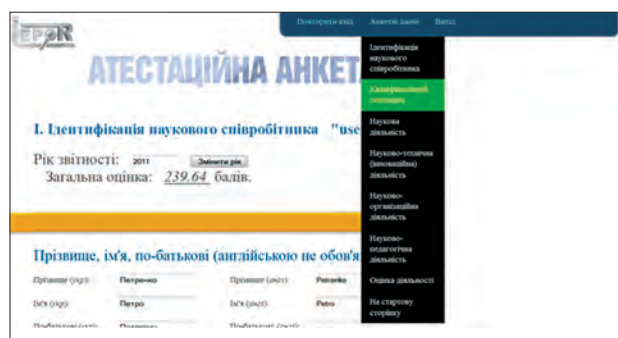

Section selection menu

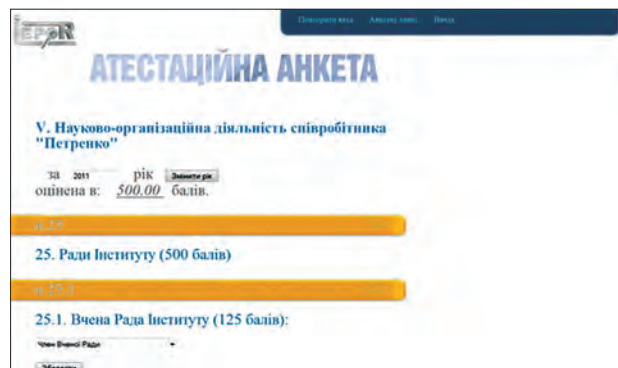

R&D Activities Section

## IPR Protection

IPR1, IPR3

## COMPUTER EXPERT SYSTEM FOR PREDICTING AQUEOUS SOLUBILITY, LIPOPHILICITY, AND MUTAGENICITY OF BIOLOGICALLY ACTIVE COMPOUNDS

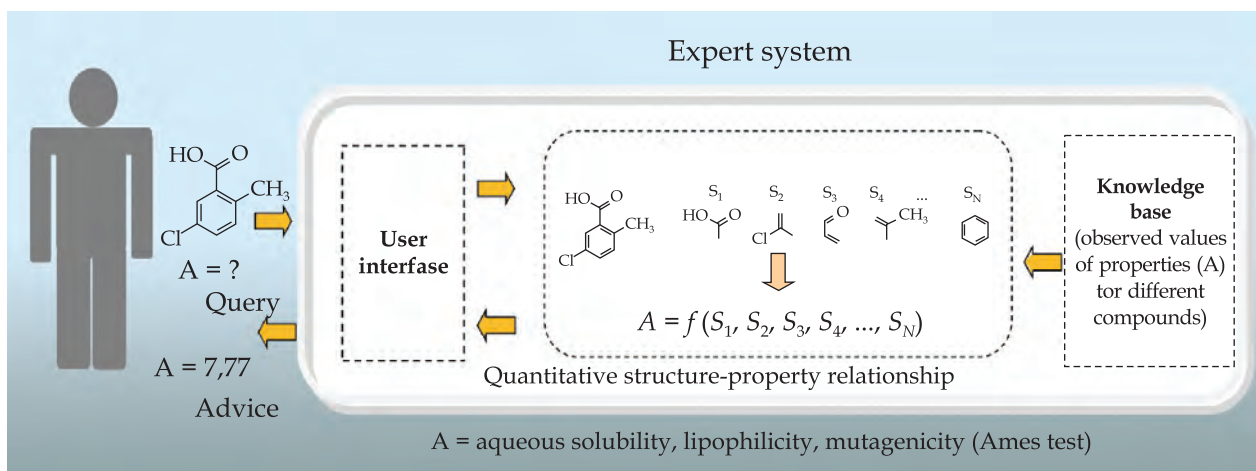

### Areas of Application

Based on the chemical structure of organic compounds the expert system predicts their aqueous solubility, lipophilicity, and mutagenicity (the Ames test). The predicted values of these properties can be used as filter in medicinal chemistry to create new drugs and bioactive compounds. The system enables to replace expensive screening of these properties by computer experiment

### Specification

The expert system is implemented as computer program designed for using in the operating system Windows XP / Vista / 7/8/10. Recommended configuration: Pentium III or higher, 1 Gb RAM, 250 Mb hard disk space. Input information: file with the chemical structure of organic compound. Output information: predicted values of properties

### Advantages

The expert system has no analogs in Ukraine and meets international standards predicting aqueous solubility, lipophilicity, and mutagenicity of biologically active compounds

### Stage of Development. Suggestions for Commercialization

IRL8, TRL5  
Installation of program and staff training, upon request

### IPR Protection

IPR2

### Contact Information

Tetiana V. Mikhaylova, A.V. Bogatsky Physico-Chemical Institute of the NAS of Ukraine;  
+38 067 706 10 94, e-mail: office.physchem@nas.gov.ua



## CORE OF HIGH-PERFORMANCE PROCESSOR WITH HIGH-LEVEL INNER LANGUAGE

### Areas of Application

The high-performance processor core is a microprocessor electronic component based on programmable logic device to be used for creating advanced sonar, communication, and navigation systems for defense and civil purposes

### Specification

Fixed bitness of 24/48 binary bits;  
field command structure;  
super von Neumann architecture;  
reducing parallelism as method of computing organization;  
three-address data addressing;  
fixed 96-bit instruction format;  
depth of nested loops is 32;  
speed is 100 megaflops



High-performance processor core based on programmable logic device

### Advantages

There are no counterparts in Ukraine. The high-level inner language and merger of data computations with predicate computations into one command provides reducing length of program code and lowering costs of applied program development

### Stage of Development.

#### Suggestions for Commercialization

IRL7, TRL5  
Manufacture of small series, delivery, warranty service, and staff training are provided upon request

### IPR Protection

IPR1, IPR2

### Contact Information

*Sergii V. Yershov*, Glushkov Institute of Cybernetics of the NAS of Ukraine;  
+38 044 526 41 78, e-mail: ErshovSV@nas.gov.ua

# CORPORATE CLOUD PLATFORM FOR BIG DATA INTELLIGENT PROCESSING

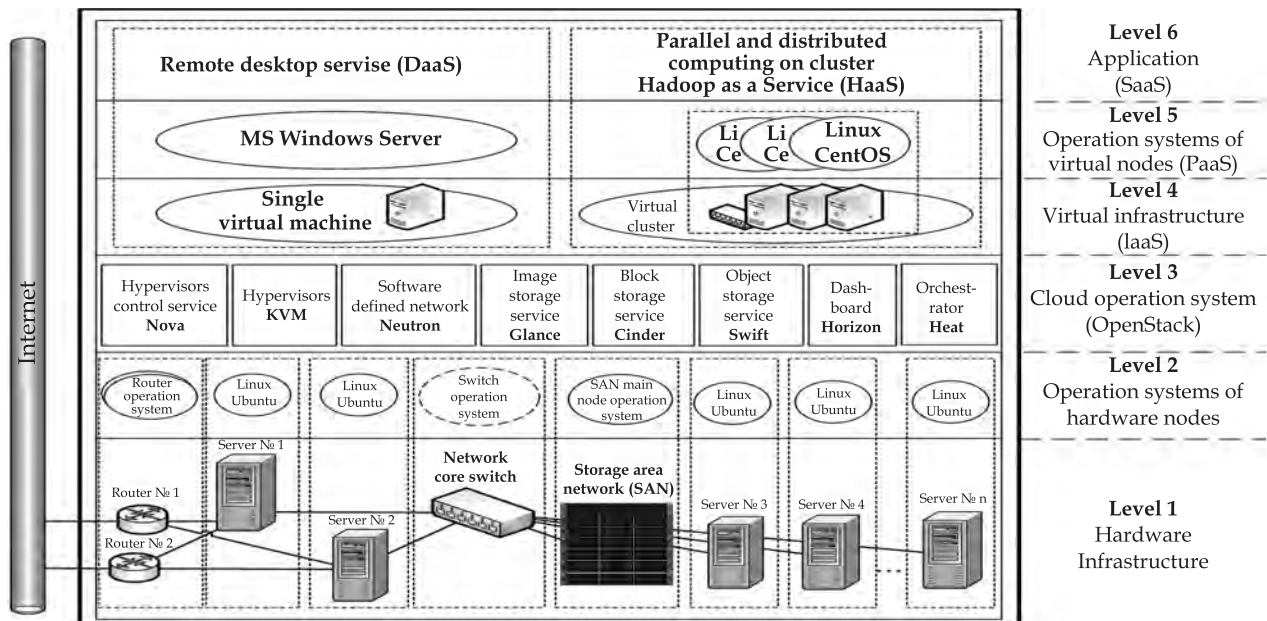

## Areas of Application

Advanced platform to manage data and analytic computations for decision making with equipment located on enterprise's site

## Specification

Resource is limited by the number and hardware characteristics of nodes at the platform physical level. The number of units in the platform is not limited. OpenStack open source product is used as a cloud operating system. Parallel distributed computations in cluster environment are provided by common software based on open source Apache Hadoop framework

## IPR Protection

IPR1

## Advantages

The solution increases data processing speed, resource scalability, and virtual infrastructure mobility. The platform enables computerizing high-qualification administrative tasks. Sharing of resources raises efficiency and reduces costs of platform services. The solution negates the need for powerful PCs in the workplaces, etc.

## Stage of Development.

### Suggestions for Commercialization

IRL3, TRL2

Local platforms for Big Data processing

## Contact Information:

Anatol P. Lozinskyi, International Research and Training Center for Information Technologies and Systems of the NAS of Ukraine and the Ministry of Education and Science of Ukraine; +38 044 228 77 11, +38 095 065 83 37, e-mail: anatol@ovo.com.ua

## DESIGN, COMPUTATION, AND SIMULATION OF PHYSICAL PROCESSES

### Areas of Application

Development and improvement of technologies in the sphere of chemical engineering, power engineering, and other industries using advanced computer technologies for design, computation, analysis, and simulation of physical processes

### Specification

Strength and pressure analyses;  
heat transfer (steady and unsteady);  
hydrodynamics (including dispersive media);  
thermochemical calculations;  
and interdisciplinary analysis

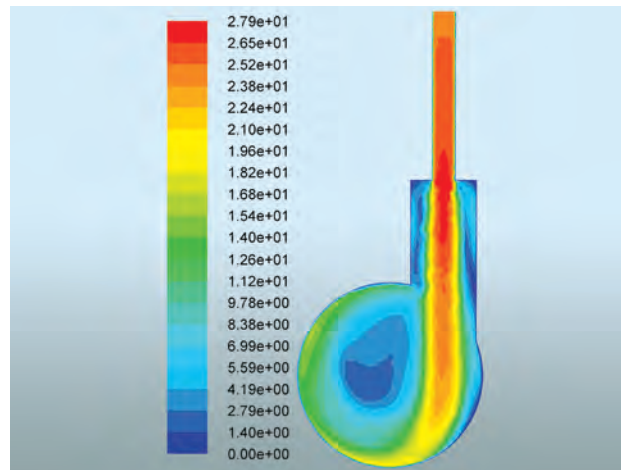

Simulation of methane combustion in the cyclone type reactor

### Advantages

3D device design using advanced technologies is a key to better and more qualitative calculations and analysis of technology and processes and prevents design mistakes. The simulation of physical processes enables to carry out a virtual experiment instead of expensive full-scale one and gives valuable technical information

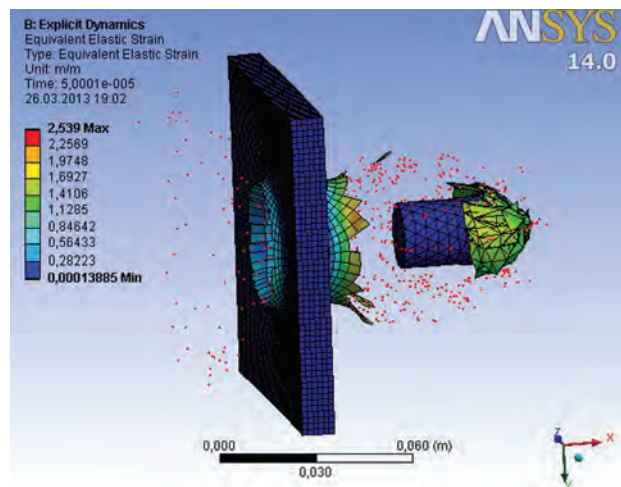

Simulation of projectile burst and armor damage for a projectile flight speed of 2000 m/s

### Stage of Development. Suggestions for Commercialization

IRL7, TRL8

Calculations or development of appropriate technology, manufacture, delivery, warranty service of device (plant or factory), and staff training are provided upon request

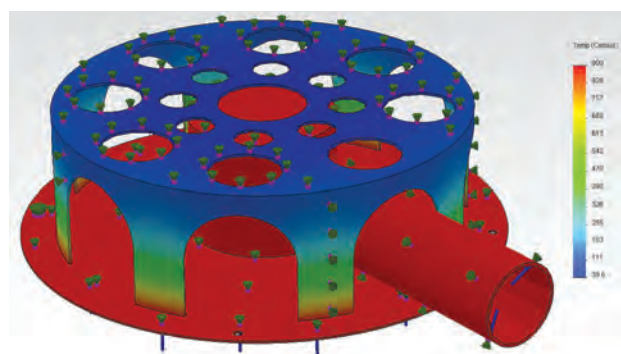

Simulation of natural convection heat transfer between a part of device and environment

### IPR Protection

IPR1, IPR2

### Contact Information

*Eugene V. Strativnov*, Institute of Gas of the NAS of Ukraine; +38 044 456 44 71, +38 095 182 73 43, +38 097 306 18 46, +38 044 456 88 30, e-mail: [estrativnov@gmail.com](mailto:estrativnov@gmail.com), Skype: strativnov

## DICTIONARIES OF UKRAINE INTEGRATED LEXICOGRAPHICAL SYSTEM



### Areas of Application

Dictionaries of Ukraine electronic edition is designed to provide users with lexicographical information about Ukrainian language and is useful for linguists, lexicographers, philology students as a tool to support their linguistic researches, as well as for ordinary users: school and university students and all those interested in Ukrainian

### Specification

The edition consists of the following dictionary modules:

1. Transcription;
2. Inflection;
3. Phraseology;
4. Synonymy; and
5. Antonymy

The system requirements for the front-end and the back-end components:  
OS Windows XP SP3 or higher

### Stage of Development. Suggestions for Commercialization

IRL5, TRL6

The Ukrainian version is available for free on the Ukrainian Linguistic Portal website. CD\_ROM release is possible. Redesign for other languages on paid basis

### Advantages

The integrated information system for Ukrainian language studies is re-designable for any other language and has no analogs in Ukraine. It has advanced software tools for lexicographical work with information theory and technologies of lexicographical systems

### IPR Protection

IPR3

### Contact Information

*Volodymyr A. Shyrovkov*, Ukrainian Lingua-Information Fund of the NAS of Ukraine;  
+38 044 525 86 75, e-mail: vshirokov48@gmail.com

## DICTIONARY OF UKRAINIAN LANGUAGE VIRTUAL LEXICOGRAPHICAL LABORATORY

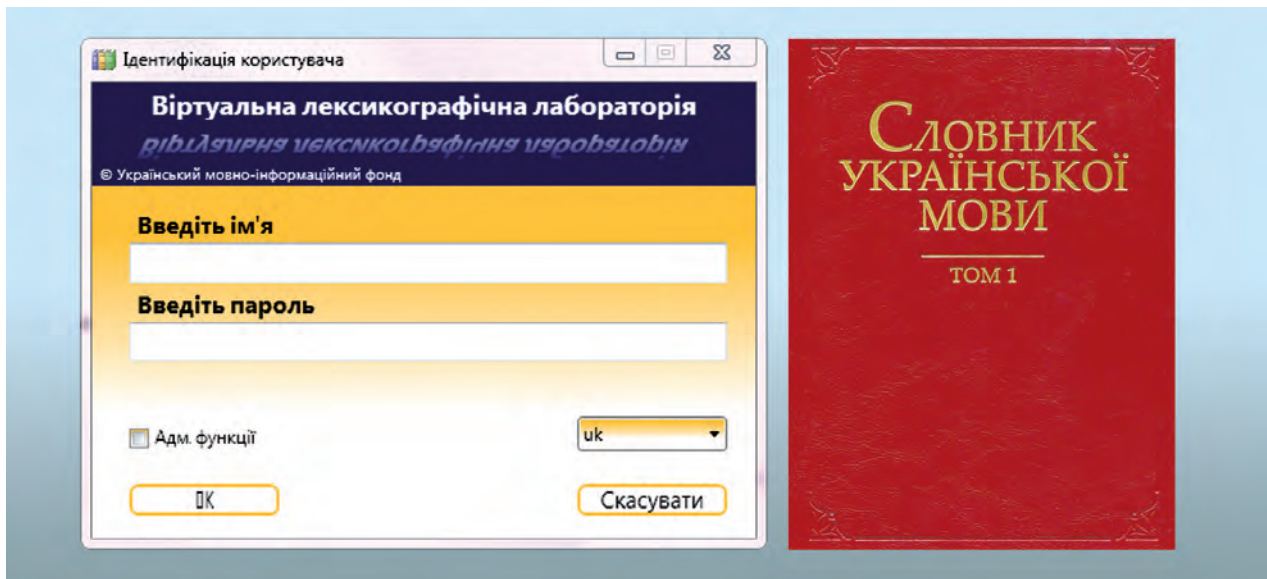

Dictionary of Ukrainian Language Virtual Lexicographical Laboratory. The user interface

### Areas of Application

*Dictionary of Ukrainian Language* is designed to support the process of creating the dictionary of Ukrainian language by geographically distributed group of lexicographers in virtual mode. It is aimed at the linguists, lexicographers, philology students, etc.

### Specification

The system requirements for the front-end and the back-end components:  
OS Windows XP SP3 or higher

### Advantages

The distributed virtualized information system for compiling and developing explanatory dictionaries, which is suitable for re-designing for any other language has no analogs in Ukraine. Its advanced software tools enable common distributed lexicographical work with the usage of information technologies of virtualization, service-oriented architecture, theory and technology of lexicographical systems

### Stage of Development. Suggestions for Commercialization

IRL5, TRL6  
Free trial version is available via Internet for research institutions and professionals involved in compilation of dictionaries.  
Full-featured system is developed on paid basis

### IPR Protection

IPR2

### Contact Information

*Volodymyr A. Shyrovokov*, Ukrainian Lingua-Information Fund of the NAS of Ukraine;  
+38 044 525 86 75, e-mail: vshirokov48@gmail.com

## DocSORTER AUTOMATIC TEXT CLASSIFICATION SYSTEM



### Areas of Application

The system is designed for detection and analysis of signs of thematic or emotional class of texts. It is aimed at news agencies and analytic centers processing information from open sources

### Specification

The system detects the text elements corresponding to certain concepts. This enables to detect the thematic elements containing in the text and the text subject. The system is based on reference texts stored in topic directories, so it can distinguish various topics such as physics, mathematics, politics, sports, etc.

If there is a set of emotionally colored reference texts, such as movie reviews, the algorithm can be used for sentiment analysis of the texts

Requirements: Windows XP operating system or higher

### Stage of Development. Suggestions for Commercialization

IRL3, TRL5  
Customization to types of texts and requirements of end users, upon request

### Advantages

As compared with other systems, DocSorter is designed to work with English, Ukrainian, and Russian. Due to the use of semantic analysis, in particular, UkrWordNet database, the system is aimed at semantic similarity of text elements instead of text vocabulary

### IPR Protection

IPR1, IPR3

### Contact Information

*Volodymyr Y. Taranukha*, International Research and Training Center for Information Technologies and Systems of the NAS of Ukraine and the Ministry of Education and Science of Ukraine; +38 044 502 63 19, e-mail: dep165@irtc.org.ua

## FLOOD MONITORING SERVICE



Map of flood areas based on satellite data processing

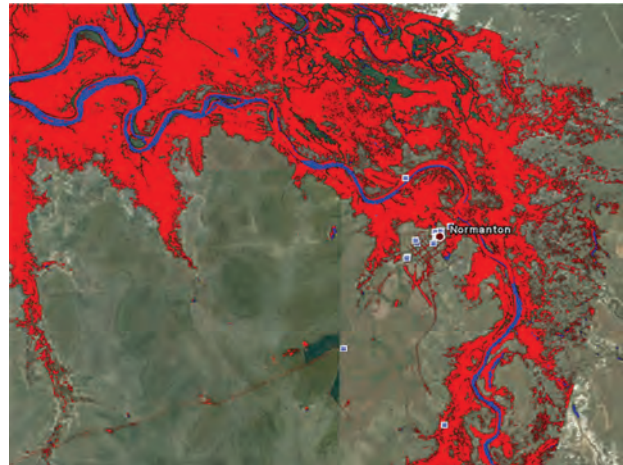

Digital map of flooded areas in Australia (17.02.2009)

### Areas of Application

Risk assessment and monitoring of emergencies, in particular, floods, including evaluation of moisture content in snow banks based on radar data; provision of information support for decision-making to public authorities and international organizations; flood mapping based on satellite data; maps integration into socioeconomic information; provision of information resource with automatic receipt of data from the UN-Spider to monitor flooding

### Advantages

For the time being, there are no analogs. The product is notable for the following features: dynamic formation of system content; easy visualization of geospatial information and system operation; use of international standards for information exchange and supply. The service has been tested for solving problems of the UNO UN-SPIDER Regional Support Office using Sentinel-1 data and adapted for the European Space Agency

### Specification

The flood mapping based on satellite radar data includes preprocessing (orthorectification and geo-referencing) and content processing (segmentation and further classification of images using Kohonen neural networks)

### Stage of Development. Suggestions for Commercialization

IRL6, TRL7  
The product is ready for use by end users; supporting services provided

### IPR Protection

IPR1

### Contact Information

*Olena O. Nizhnichenko*, Institute for Space Research of the NAS of Ukraine;  
+38 044 526 62 53, e-mail: elena@ikd.kiev.ua

## HIGH-ACCURACY POSITIONING BASED ON ORBITAL DATA ONLY

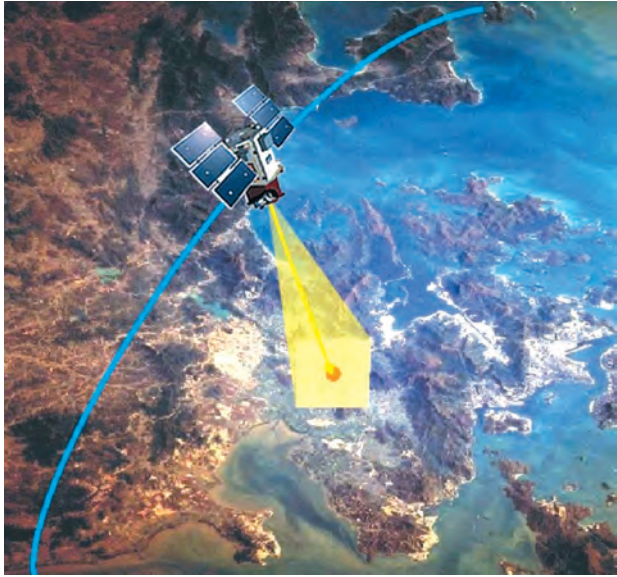

Satellite image of polygon with known point landmarks

### Advantages

The method enables accurate positioning based on satellite images, after in-flight geometric calibration with the use of data on several (1–3) known point landmarks on ground polygon

### Areas of Application

The method is to be used for processing the Earth's surface satellite images by the ground data processing center for the purposes of mapping, wildlife management, natural resource management, and monitoring of their conditions

### Specification

The root mean square error of coordinate determination is approximately 10 m

### IPR Protection

IPR1

### Stage of Development. Suggestions for Commercialization

IRL3, TRL4

Computer program for the ground data processing center

### Contact Information

*Dmytro V. Lebediev*, International Research and Training Center for Information Technologies and Systems of the NAS of Ukraine and the Ministry of Education and Science of Ukraine; +38 044 526 21 89, e-mail: dep180@irtc.org.ua



## ICaS-ColorPrint® INFORMATION TECHNOLOGY FOR COLOR PRINTING

### Advantages

The existing technologies use the classic principle of color printing by black and three or more colors. ICaS-ColorPrint® is a unique technique that provides ideal conditions for color printing: maximum limit of colored inks is 200%; maximum limit of all inks (including black) is 300% that exceeds the requirements of state-of-the-art color printing standards; high quality of color reproduction; and essential saving of colored inks (about 50–70%)

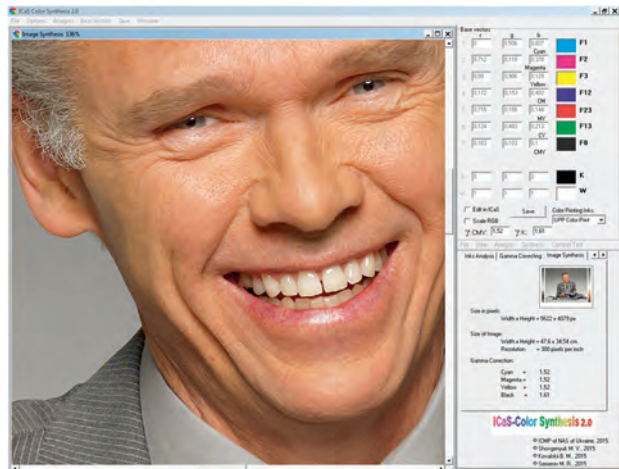

ICaS-Color Synthesis 2.0 window

### Areas of Application

The technology is to be used for prepress artwork setup for digital and offset color printing of illustrated books

### Stage of Development. Suggestions for Commercialization

IRL8, TRL7

Original software and staff training

### Specification

The technology uses a new principle of color printing based on analytical methods for analysis and synthesis of color images. Every pixel is reproduced only by black and two other colors. The original software enables original image separation, color correction, printed image synthesis, and color overlay

### IPR Protection

IPR3, IPR4

### Contact Information

Oleksandr L. Ivankiv, Institute for Condensed Matter Physics of the NAS of Ukraine;  
+38 032 276 11 57, e-mail: oiva@icmp.lviv.ua

## IMAGE PROCESSING BASED INFORMATION TECHNOLOGY FOR AUTOMATIC AIRBORNE OBJECT TRACKING



Object tracking against a background of glittering water



Object tracking against a rugged-relief surface

### Areas of Application

The technology is to be used in systems for target object tracking

### Specification

The technology applies to real-time systems. It provides a reliable automatic object tracking in the following conditions: on the background of surfaces with various textures; significant changes in the object shape (spatial orientation) along the whole tracking distance; sudden changes in the object scale; defocusing of the object; varying brightness and contrast of the image

### IPR Protection

IPR2

### Advantages

It provides a better computational speed as compared with the state-of-the-art analogs

### Stage of Development. Suggestions for Commercialization

IRL3, TRL2  
Customization and software installation, upon request

### Contact Information

*Olena H. Revunova*, International Research and Training Center for Information Technologies and Systems of the NAS of Ukraine and the Ministry of Education and Science of Ukraine; +38 044 526 25 49, e-mail: helab@i.com.ua

## INFORMATION SYSTEM FOR INTELLECTUAL SUPPORT OF MEDICAL SERVICES PROVISION

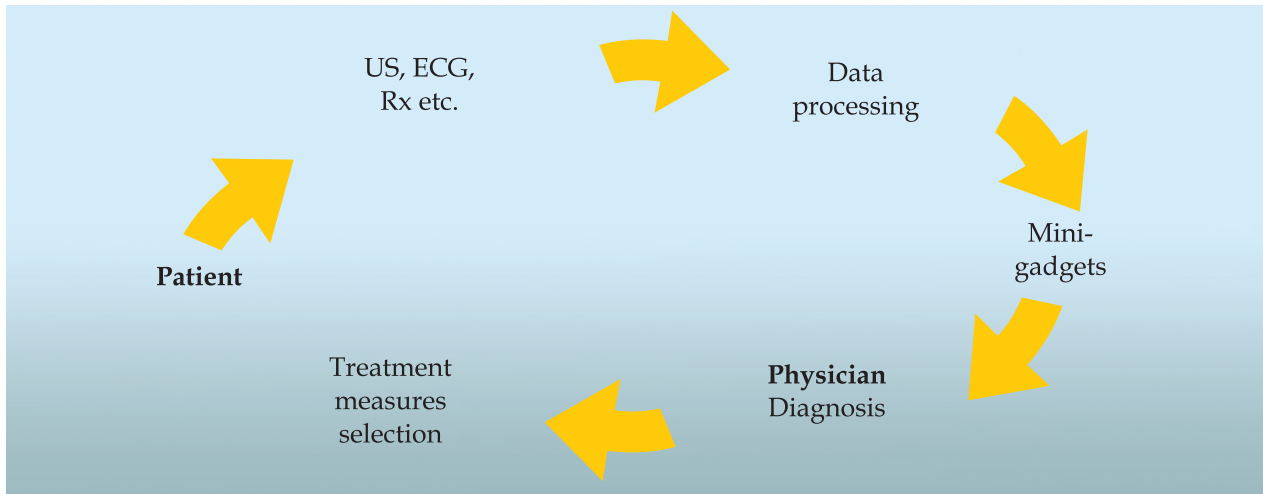

Flowchart of operation of the information system for intellectual support of medical services

### Areas of Application

The system aims at providing information support of decision-making in diagnosis, choice of treatment option, etc. at healthcare facilities

### Specification

The system is based on creating information applications for mobile devices and telemedicine tools in the diagnosis and choice of treatment option with the use of real-time digital medical data

### Stage of Development. Suggestions for Commercialization

IRL3, TRL4  
The system with options of author's installation and maintenance is proposed to developers of information systems for medical institutions

### Advantages

Unlike the existing means of diagnosis based on expert judgment, this one uses methods of digital images and medical data analysis

### IPR Protection

IPR2

### Contact Information

*Olexander S. Kovalenko*, International Research and Training Center for Information Technologies and Systems of the NAS of Ukraine and the Ministry of Education and Science of Ukraine; +38 044 503 95 62, e-mail: askov49@gmail.com

## INFORMATION TECHNOLOGY FOR COMPREHENSIVE EVALUATION OF COMPLEX HIERARCHICAL NETWORK SYSTEMS

### Areas of Application

The technology is to be used for real-time evaluation of the state and quality of operation of complex hierarchical network systems, for example, urban or regional transport systems, water, gas, and power supply systems, etc.

### Specification

The technology is based on combining local, prognostic, interactive, and aggregated methods for evaluation of the main components of complex dynamical system and using an adjusted score system and advanced software and hardware for their implementation. This technology enables to obtain a sufficiently complete and holistic view of the state and quality of operation of system elements and subsystems at all levels of partitioning

### Advantages

The technology has no analogs in Ukraine and in the world. Usually, the existing approaches to evaluation only visualize the source data about the quality of system operation and use the simplest methods of aggregation and forecasting. This technology makes it possible to localize emergency situations with a reasonable accuracy and to forecast their further development

### Stage of Development. Suggestions for Commercialization

TRL5, TRL4  
Customization of technology for evaluation of complex system as a whole or its separate components in specific subject area, transfer of evaluation technology, and staff training, upon request

### IPR Protection

IPR1, IPR2

### Contact Information

*Mykhailo S. Yadzhak*, Pidstryhach Institute for Applied Problems of Mechanics and Mathematics of the NAS of Ukraine; +38 032 258 5169, e-mail: yadzhak\_ms@ukr.net

# INFORMATION TECHNOLOGY FOR MULTIFUNCTIONAL AUTONOMOUS MOBILE ROBOT CONTROL

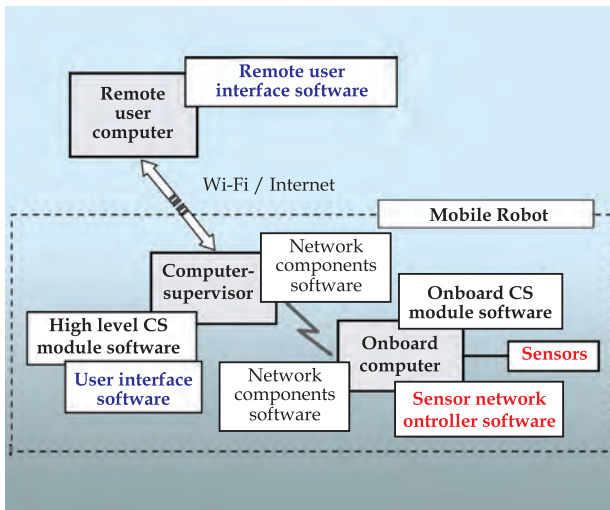

Software structure of multifunctional autonomous MR control system (CS)



Experimental multifunctional autonomous MR with intelligent control

## Areas of Application

The technology can be used in mobile robots (MR) for indoor patrolling and inspection; physical and information assistance, including assistance to people with disabilities; laboratory training complexes for practical lessons and research

## Specification

The technology provides execution of autonomous complex tasks and accumulation of information about the surrounding objects by MR in uncertain environment; user communication with MR via easily perceived images and acoustic messages using remote access tools; and performance of tasks by MR team

## IPR Protection

IPR1

## Advantages

Original concept of intelligent control activating subsystem configuration; two-module principle of information processes "environment perception ↔ goal-oriented behavior" like in the biological systems; complete complex of information technology software solutions for MR control system – from the bottom level of control up to the advanced user interface

## Stage of Development. Suggestions for Commercialization

IRL3, TRL2  
Customization of software solutions for autonomous robot control system and installation on the multifunctional indoor MR, upon request

## Contact Information

Olga M. Sukhoruchkina, International Research and Training Center for Information Technologies and Systems of the NAS of Ukraine and the Ministry of Education and Science of Ukraine; +38 044 502 63 13, e-mail: sukhoru@irtc.org.ua

## INPARCOM\_PG INTELLIGENT PERSONAL SUPERCOMPUTER OF HYBRID ARCHITECTURE



### Areas of Application

The computer is to be used for mathematical modeling in mechanical engineering, civil engineering, defense industry, etc.

### Specification

Double-precision (DP) computing performance: up to 3 TFlops; processor cores: from 8 to 44; GPUs: 2 NVIDIA Tesla K40; SSD drives: 1 drive from 240 GB, HDD drives: 2 drives from 1000 GB each (RAID 0.1); DP peak performance:  $2 \times 1,66$  TFlops; operating systems: OS Linux, OS Windows; intelligent software for solving tasks of computational mathematics Inpartool\_pg; applied software Lira, Nadra, and Weld-Predictions for modeling in the field of construction, mass transfer, and electric welding; resource management system TORQUE

### Advantages

There are no counterparts in the world. The computer uses an innovative function of automatic adaptive adjustment of algorithm, program, and computer's architecture to the problem properties; provides parallelization of algorithms and programs; speeds up hundredfold the problem solution in mechanical engineering, civil engineering, and defense industry; and provides a guaranteed accuracy of computing solutions

### Stage of Development. Suggestions for Commercialization

IRL6, TRL6  
Manufacture, supply, warranty service,  
and staff training, upon request

### IPR Protection

IPR3

### Contact Information

*Sergii V. Yershov*, Glushkov Institute of Cybernetics of the NAS of Ukraine;  
+38 044 526 41 78, e-mail: ErshovSV@nas.gov.ua

# INSERTION MODELING SYSTEM

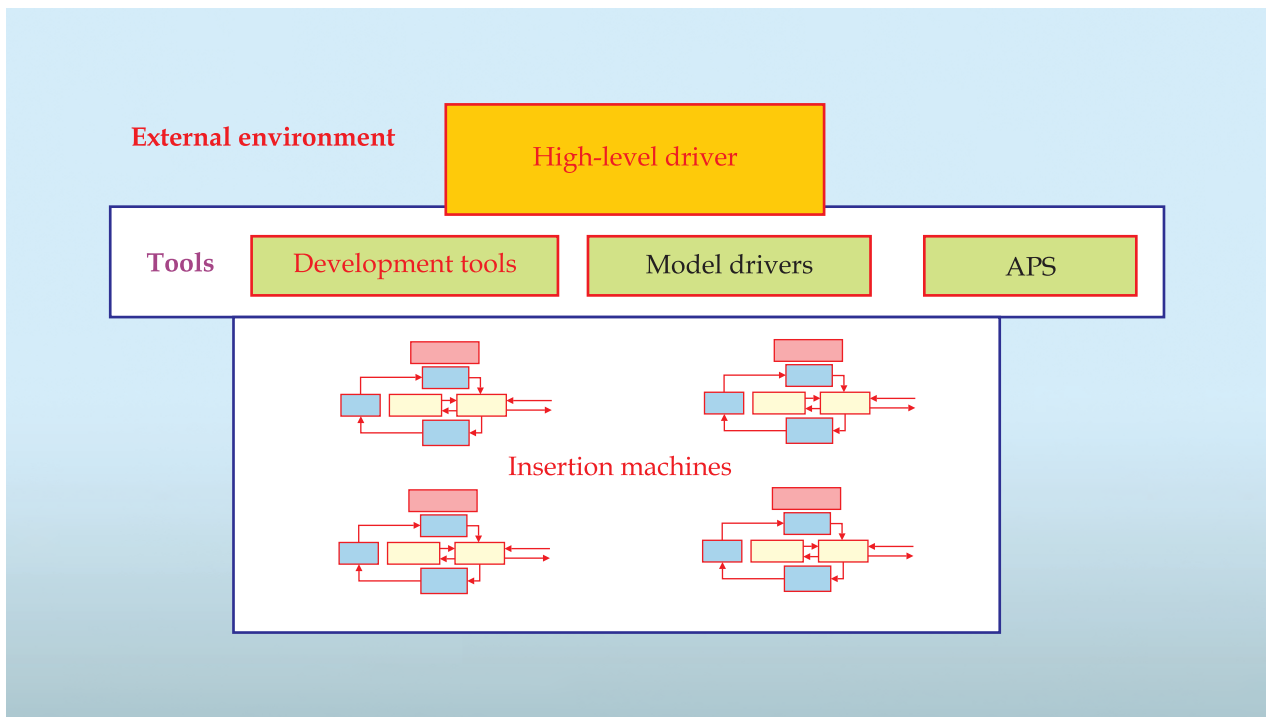

## Areas of Application

The system is aimed at developers of software for studying agents or processes interacting within an environment that defines and puts limitations on such interaction

## Specification

|  |      |
|--|------|
| Verification completeness of the system of interest, % | ~100 |
| Coverage of the states of the system of interest, %    | ~100 |
| Coverage of the traces of the system of interest, %    | ~100 |

## Advantages

There are no counterparts in Ukraine. The system is 2–3 times cheaper than the foreign competitors. A significant advantage over the world analogs is effective application of symbolic modeling and predicate transformer semantics for ensuring a high-level completeness of software system verification and testing

## IPR Protection

IPR1, IPR3

## Stage of Development. Suggestions for Commercialization

IRL6, TRL5  
Commercial versions of software system and staff training, upon request

## Contact Information

Sergii V. Yershov, Glushkov Institute of Cybernetics of the NAS of Ukraine;  
+38 044 526 41 78, e-mail: ErshovSV@nas.gov.ua

# INTEGRATED SOFTWARE TOOL ENVIRONMENT FOR KNOWLEDGE REPRESENTATION AND PROCESSING (SLM-TECHNOLOGY)

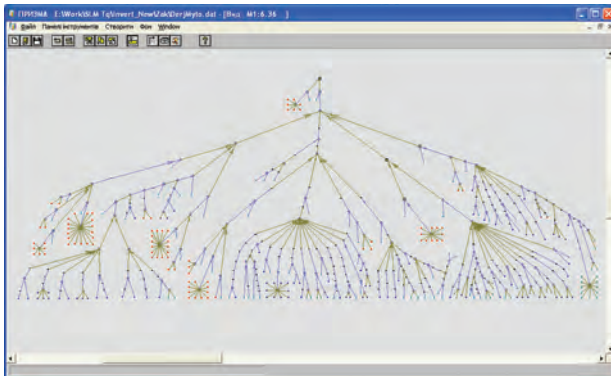

Example of knowledge representation in logical-computing semantic network by means of SLM-technology

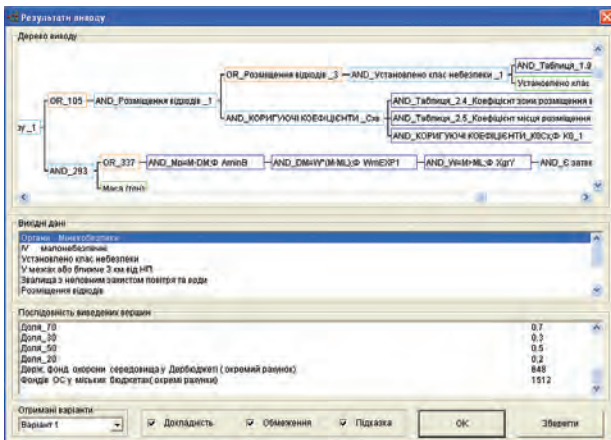

Example of display of inference results by means of SLM-technology

Stage of Development.  
Suggestions for Commercialization

IRL6, TRL4  
Customization of SLM-technology,  
upon request

## Areas of Application

The product is to be used for representing and processing clear and fuzzy knowledge about the subject areas in which the tasks are reduced to diagnosis, interpretation, evaluation, repair, monitoring, and so on

## Specification

The SLM-technology provides representation of procedural-declarative knowledge using the newest knowledge representation model (logical-computing semantic network) and knowledge processing by the forward-chaining method.

The SLM-technology enables to automatically perform static verification of represented knowledge, which ensures consistency and integrity of represented knowledge, as well as generation of set of test cases required for the empirical testing of represented knowledge

## Advantages

Unlike the well-known analogs, this product enables representing and processing both clear and fuzzy knowledge; correctly solving the tasks of automatic detection of factual errors in represented knowledge; and supporting the empirical testing of represented knowledge

## IPR Protection

IPR1, IPR3

## Contact Information

Gregory B. Moroz, Institute of Software Systems of the NAS of Ukraine;  
+38 044 526 33 09, e-mail: mgb@isofts.kiev.ua



# INTEGRATED TOOLKIT FOR PROGRAM DESIGN AND SYNTHESIS (IDS) AUTOMATED SYSTEM

## Algebraic form (a formula)

$$ALT = ([l > r | P] T(l, r | P) * R(P), R(P)).$$

## Natural-linguistic (a text)

ALT =  
 == IF 'Elements  $l > r$  at the pointer  $P$  in the array  $A$ '  
 THEN "Transpose the elements  $l, r$  at the pointer  $P$  in the array  $A$ "  
 THEN  
 "Move the pointer  $P$  over the array  $A$  by one element to the right"  
 ELSE "Move the pointer  $P$  over the array  $A$  by one element to the right"  
 END IF

## Flowgraph

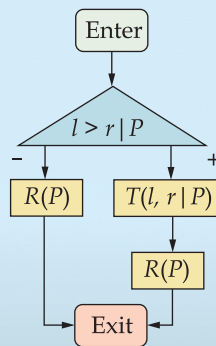

## User

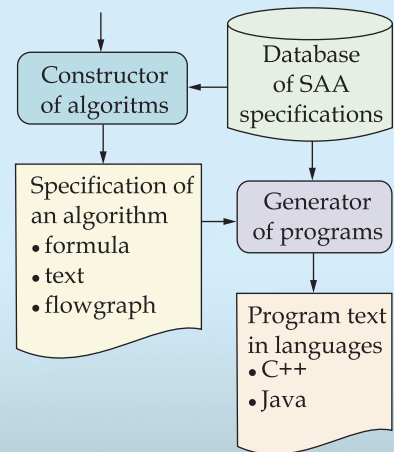

The forms of algorithm representation in IDS system (to the left), the process of program development in IDS system (to the right)

## Specification

The toolkit is based on the systems of Glushkov algorithmic algebras (SAA) for formal design of algorithms in algebraic, natural-linguistic, and graph forms (the left-hand scheme). The process of software development in IDS is shown in the right-hand scheme

## Areas of Application

The toolkit is to be used for automated construction of high-level specifications (schemes) of sequential and parallel algorithms and generation of programs in C++ and Java languages for various subject domains (for instance, weather forecasting)

## Advantages

The system uses specifications of the algebra of algorithms represented in natural linguistic form, which facilitates understanding of algorithms and achievement of required program quality. The method for automated construction of syntactically correct algorithm schemes prevents syntax errors during algorithm design

## Stage of Development.

### Suggestions for Commercialization

IRL7, TRL7  
 Toolkit installation files  
 and user training, upon request

## IPR Protection

IPR3

## Contact Information

Gregory B. Moroz, Institute of Software Systems of the NAS of Ukraine;  
 +38 044 526 33 09, e-mail: mgb@isofts.kiev.ua

# INTELLIGENT MULTI-AGENT SYSTEM FOR CLINICS

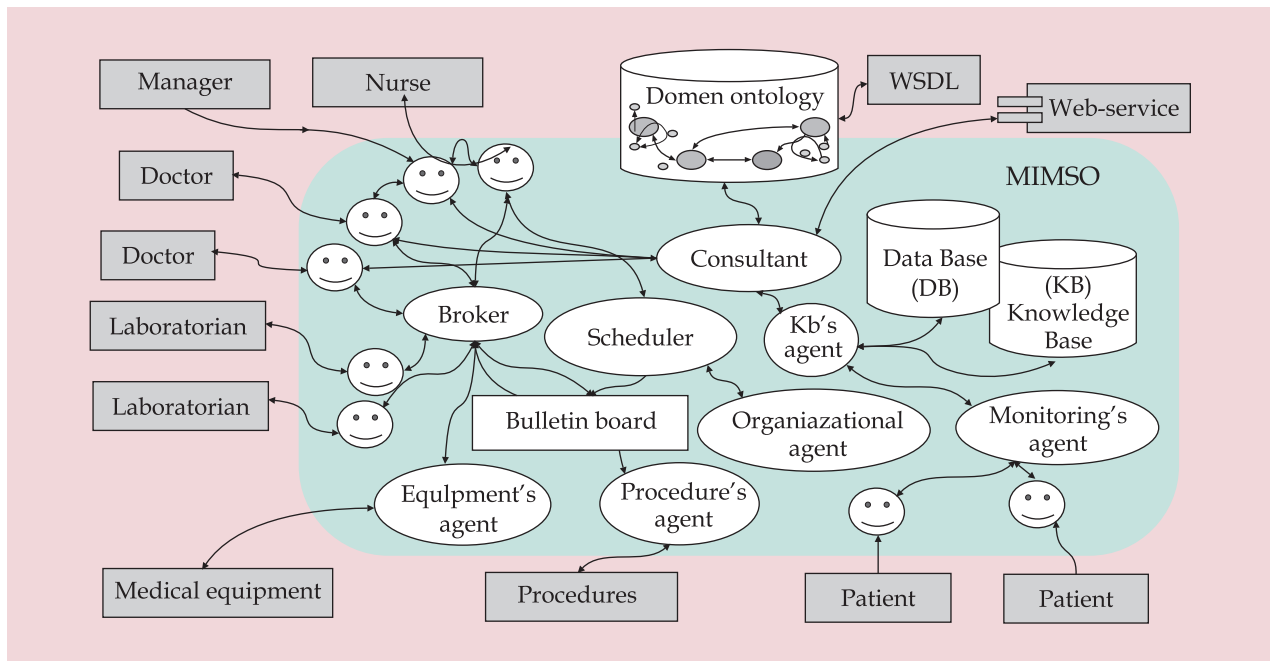

Architecture of multi-agent intellectual medical system (MIMSO)

## Areas of Application

The system is to be used for raising efficiency of healthcare institutions through automation of routine tasks and provision of real time access to information and knowledge acquisition for clinic staff. The system enables reducing the duration and improving the quality of patient treatment

## Specification

The product is a client-server information system based on local area network with Internet access. The number of agents of medical staff and patients is up to three thousand. The system provides mobile ontological knowledge base and knowledge reuse, is easily updatable and expandable

## Advantages

Unlike the analogs, this system uses state-of-the-art innovative technologies to represent the formal knowledge of the subject area as ontologies. To this end, algorithms, models, and methods for accumulation and use of this knowledge, as well as Internet of Things subsystem for remote monitoring of patient status have been developed

## Stage of Development.

### Suggestions for Commercialization

IRL6, TRL5

The system is ready for replication and customizable, upon request

## IPR Protection

IPR3

## Contact Information

Anatoly Ya. Gladun, International Research and Training Center for Information Technologies and Systems of the NAS of Ukraine and the Ministry of Education and Science of Ukraine; +38 044 502 63 66, +38 066 957 98 16, e-mail: glanat@yahoo.com

# INTELLIGENT TECHNOLOGY FOR DYNAMIC OBJECTS COLLISION AVOIDANCE

## Areas of Application

The technology aims at expanding targeted control areas for different types of sea vessels and aircrafts. It enables to automate a process of making timely and effective decisions in real-time conflict situations and under critical operational conditions. The technology is aimed at organizations engaged in development and operation of control systems

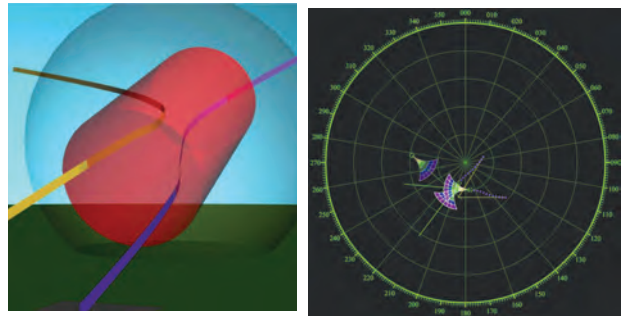

Technology application to a conflict situation (a 3D model of aircraft traffic, to the left) and proposed interface of the collision avoidance system (to the right)

## Specification

The technology enables to integrate advanced approaches to intelligent control and to work out effective solutions concerning safe collision-avoidance maneuvers at various levels of conflict complexity; integrated information about autonomous or coordinated decisions in intensive traffic areas under natural, legal, and weather restrictions; flexible routes of dynamic objects taking into account emergency situations, economic and power criteria, ecological requirements and comfort of control

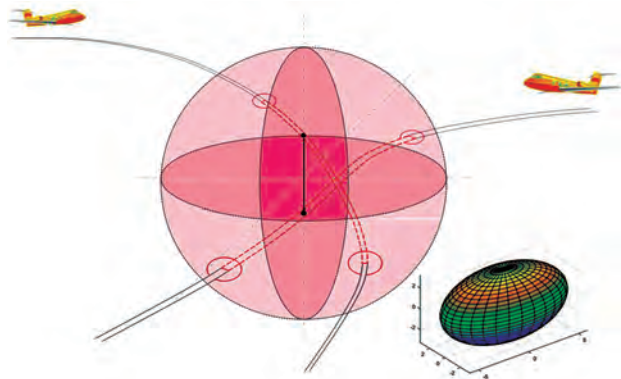

Simulation of the conflict situation dynamics for two aircrafts

## Advantages

The technology has no counterparts. It enables to control dynamic objects in critical operational modes and emergency situations and to provide conditions for improving reliability, economic efficiency, and comfort taking into consideration normative requirements of ICAO (for aircrafts) and IMO (for sea vessels)

## Stage of Development. Suggestions for Commercialization

IRL6, TRL5  
Sale of software applications, designer's service, and training of personnel, upon customer's request

## IPR Protection

IPR3

## Contact Information

Serhii V. Melnikov, International Research and Training Center for Information Technologies and Systems of the NAS of Ukraine and the Ministry of Education and Science of Ukraine; +38 044 526 25 49, +38 044 526 01 58, e-mail: dep185@irtc.org.ua

## INTERACTIVE MICROPROCESSOR SYSTEM FOR EXPERIMENT COMPUTERIZATION

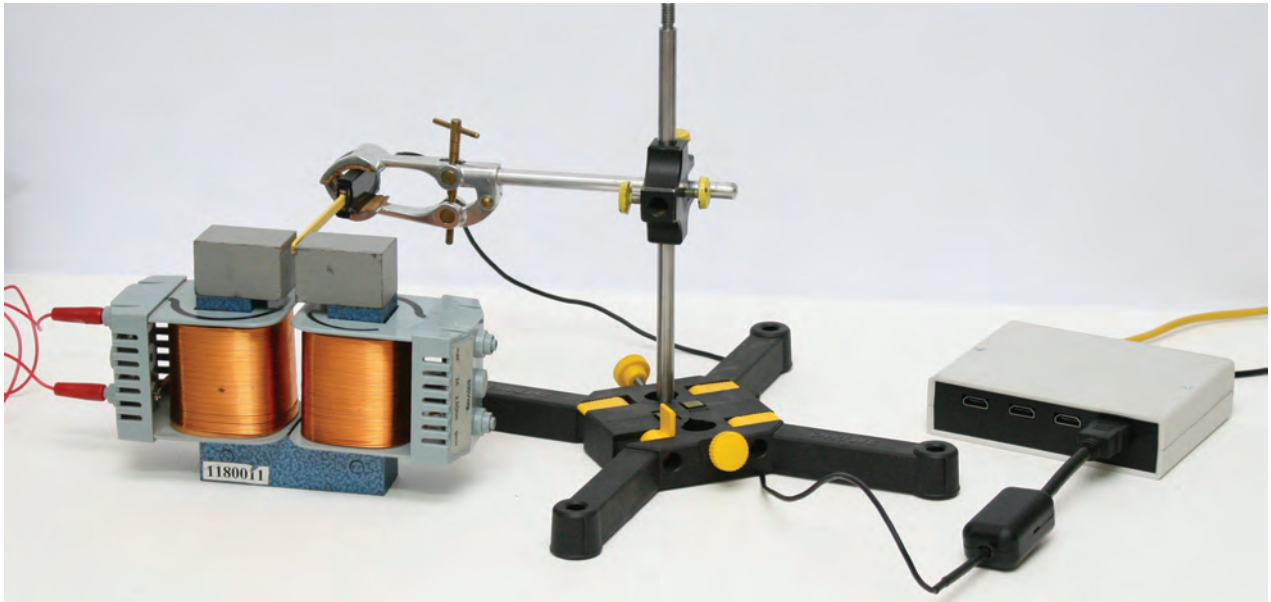

Experiment with the use of software and hardware complex

### Areas of Application

The hardware and software system is to be used for experimental data acquisition and processing as a framework for modern computer-oriented laboratories for physics experiments at educational and research establishments of Ukraine

### Advantages

The system has no counterparts in Ukraine, is considerably cheaper than the foreign analogs and possesses as good specifications as they do

### Stage of Development. Suggestions for Commercialization

IRL6, TRL5  
The options are purchase of manufacturing license or signature of license agreement  
Small-scale fabrication is possible at the Institute's capacities at investor's cost

### Specification

The modular approach enables to quickly adapt the hardware and software system to available equipment and to develop new computerized appliances. The implementation of fiber channels makes it possible to configure interactive devices and setups with remote access. The system can be helpful for multiple-access use of more expensive equipment via Internet. The system has no special requirements to user's PC. Specifications: 4 HDMI in/outputs; RJ45 slot for twisted pair wire; 4-channel 12-bit analog-digital converter; 2-channel 12-bit digital-analog converter; data rate per each channel of up to 5 kHz; 8 digital in/outputs

### IPR Protection

IPR3

### Contact Information

*Oleksii I. Voroshilo*, Institute of Applied Physics of the NAS of Ukraine;  
+38 0542 22 46 08, +38 0542 22 27 94, e-mail: voroshilo@ipfcentr.sumy.ua

# MOBILE APPLICATION FOR INFORMATION AND CONSULTING DECISION SUPPORT IN DIAGNOSIS AND RECOVERY OF SPEECH AND MOTOR FUNCTIONS AFTER BLOOD STROKE

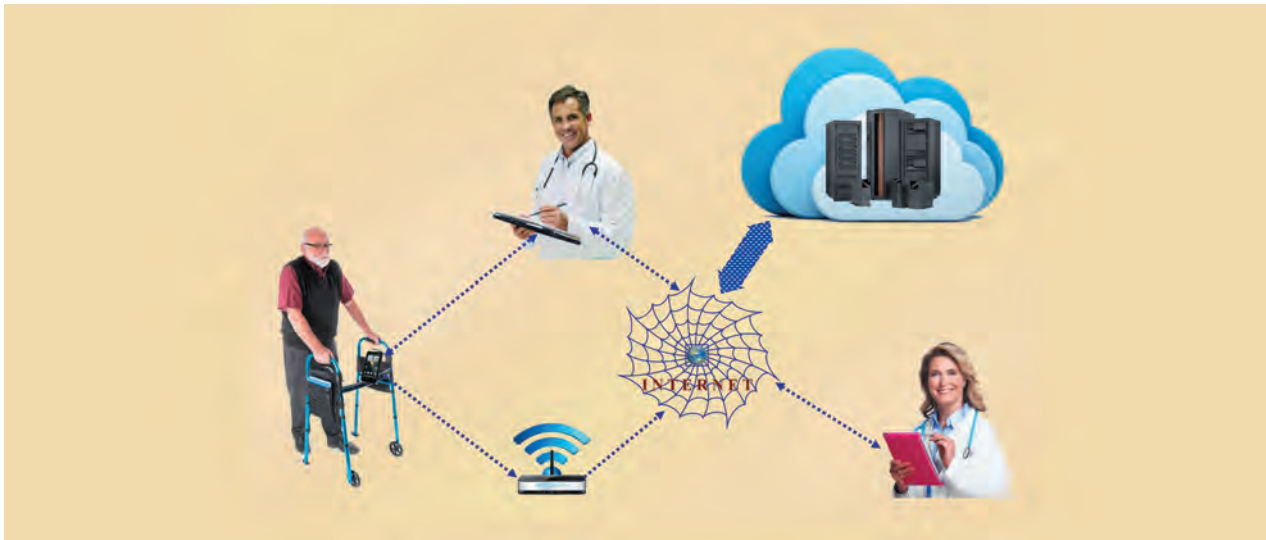

Mobile services in diagnosis and recovery of affected functions after blood stroke

## Areas of Application

The application provides a rapid quantitative assessment of neurological status and motor and speech disorders as basis for provision of individual aftercare recommendations with the help of mobile app

## Specification

The specialized mobile app for smartphones and tablets is built on Android, Java, or Linux software platforms. The application enables saving, processing, and viewing the medical data and has a networking option

## Advantages

The application has no counterparts. The new approaches to rapid assessment of patient's condition after blood stroke ensure simplicity and accessibility of survey algorithm. The unified quantitative assessment enables to objectify the recovery effectiveness. So far, there have been almost no mobile services for diagnosis, moreover, for provision of recovery plans and recommendations for after-stroke treatment of affected functions

## Stage of Development. Suggestions for Commercialization

IRL3, TRL3  
Seeking partners for market efficiency evaluation

## IPR Protection

IPR2

## Contact Information

*Oleksandr A. Kutsyak*, International Research and Training Center for Information Technologies and Systems of the NAS of Ukraine and the Ministry of Education and Science of Ukraine; +38 044 503 95 60, +38 067 770 52 61, e-mail: dep140@irtc.org.ua

# NATURAL LANGUAGE PROCESSING TECHNOLOGY BASED ON SEMANTIC INTERPRETATION OF TEXTUAL INFORMATION

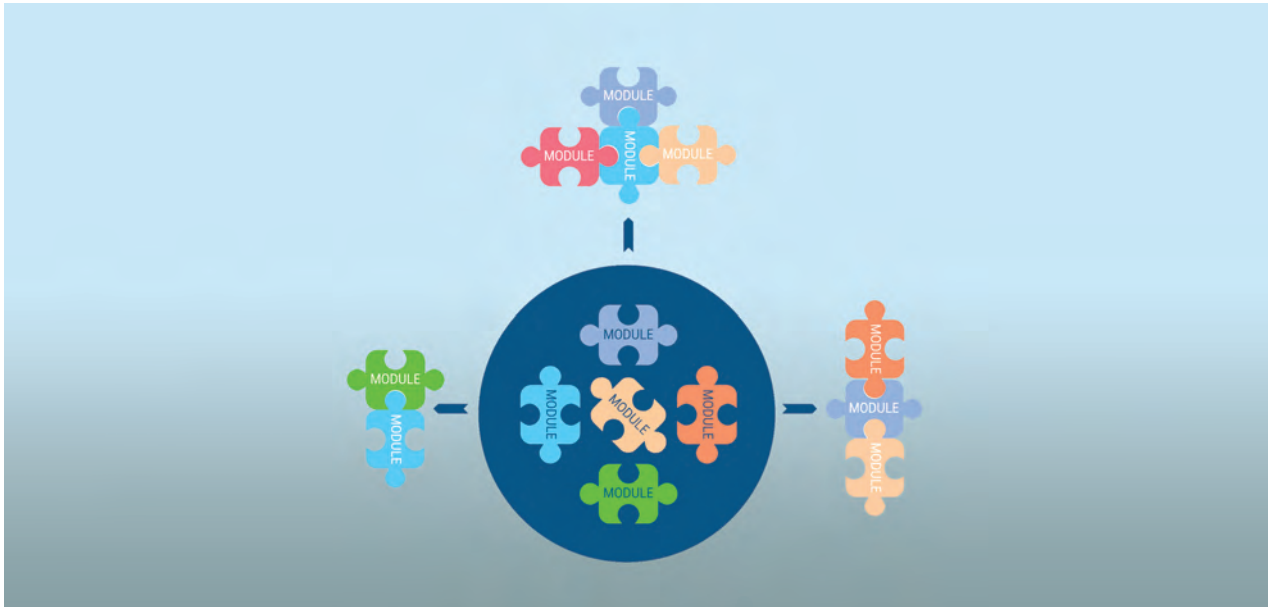

## Areas of Application

The technology is designed for a variety of NLP systems and is oriented to semantic processing and interpretation

## Specification

The technology is represented as a set of algorithms implemented as libraries and lexical-semantic database UkrWordNet. The existing algorithms enable implementing such systems as classification, clustering, summarization, authorship attribution, sentiment analysis, translation improvement and more. The system requirements: OS Windows XP or higher

## Advantages

As compared with similar technologies, the implemented NLP algorithms are primarily based on usage of lexical-semantic database and dictionaries with minimal involvement of syntactic processing. The technology supports processing of English, Ukrainian, and Russian texts. The Ukrainian component of UkrWordNet database is unique and contains over 130.000 definitions

## IPR Protection

IPR1, IPR3

## Stage of Development. Suggestions for Commercialization

IRL3, TRL5  
The use of this technology by NLP system developers will increase demand for Ukrainian linguistic toolkits

## Contact Information

*Vladimir Y. Taranukha*; International Research and Training Center of Information Technologies and Systems of the NAS of Ukraine and the Ministry of Education and Science of Ukraine; +38 044 502 63 19, e-mail: dep165@irtc.org.ua

## NAVIGATION MULTI-AGENT SYSTEM (NAVIGATION MAS)

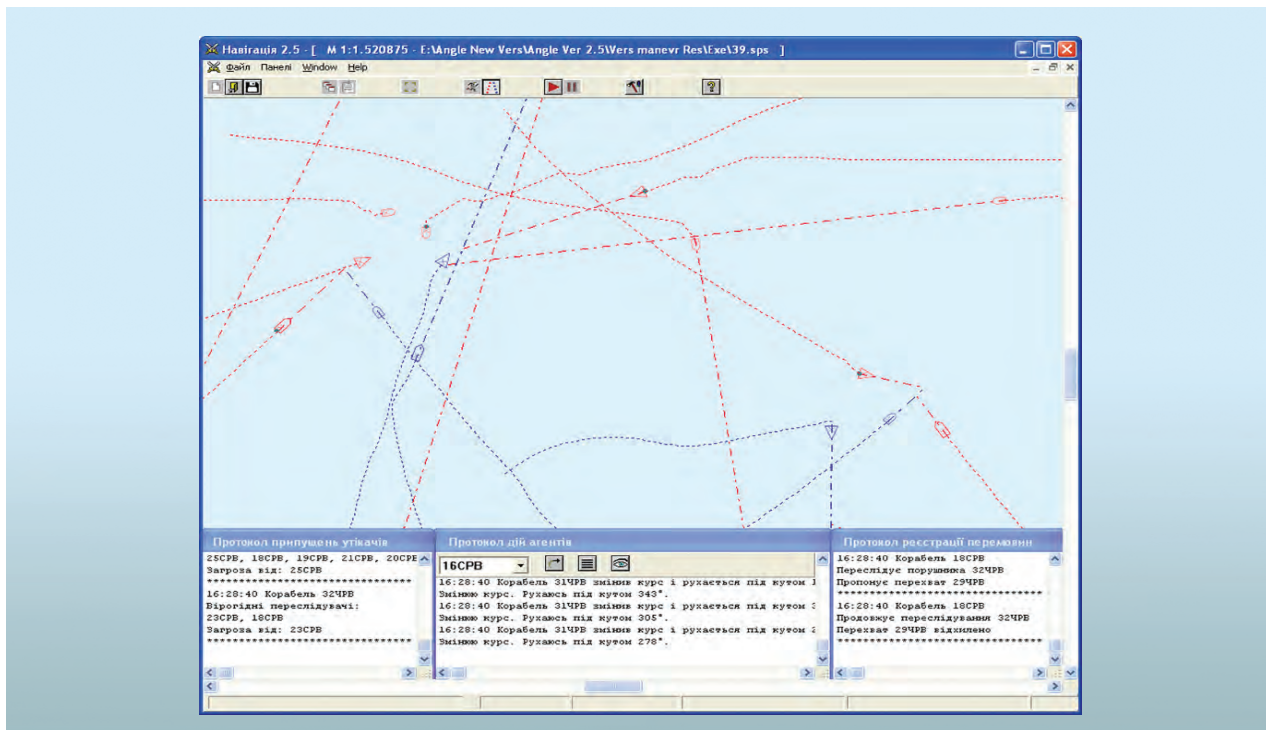

Example of multi-agent simulation of pursuit/evasion processes using *Navigation MAS* tools

### Areas of Application

The system is to be used for multi-agent simulation of pursuit/evasion processes on sea surface as real environment prototype

### Specification

Simulation of pursuit/evasion for the general case ( $n$  pursuers,  $m$  escapees, where  $n \geq m$ )

### Stage of Development.

Suggestions for Commercialization

IRL6, TRL4  
Customization of *Navigation MAS*,  
upon request

### Advantages

In contrast to well-known analogs, this system deals with the general case of pursuit/evasion processes ( $n$  pursuers,  $m$  escapees, where  $n \geq m$ ), for which the problem of optimal distribution by pursuing groups (based on the criterion of capture time minimization) is solved and agent maneuvering processes are simulated in accordance with International Regulations for Preventing Collisions at Sea

### IPR Protection

IPR1, IPR3

### Contact Information

Hryhorii B. Moroz, Institute of Software Systems of the NAS of Ukraine;  
+38 044 526 33 09, e-mail: mgb@isofts.kiev.ua

## ONBOARD DATA COLLECTION AND PROCESSING UNIT



Onboard data processing and handling unit

### Areas of Application

Space systems for monitoring the natural and manmade disasters

### Specification

|                                   |      |
|-----------------------------------|------|
| Incoming information flow, Mbit/s | ≤100 |
| Outgoing information flow, Mbit/s | ≤64  |
| Storage capacity (8 sections), GB | 512  |
| Power consumption, W              | <10  |
| Weight, kg                        | <3   |

### Advantages

There are no analogs in Ukraine. The device is as good as the best foreign counterparts. The system provides data collection and satellite control using a unique unified high-speed interface

### IPR Protection

IPR1, IPR2

### Stage of Development.

Suggestions for Commercialization

IRL3, TRL3

Manufacture, delivery, and warranty service of device, upon request

### Contact Information

*Olena O. Nizhnichenko*, Institute for Space Research of the NAS of Ukraine;  
+38 044 526 62 53, e-mail: elena@ikd.kiev.ua



## POSHUK SEARCH ENGINE



### Areas of Application

The *POSHUK* information retrieval system is designed for object-oriented search on the Internet

### Specification

The *POSHUK* search engine is a client-server cross-platform application. The server-side portion consists of the following modules: database system, information scanning module, and indexing module. The client-side portion consists of user's module, duplication check module, and abstracting service module

### Advantages

The duplication check module of *POSHUK* search engine removes duplicated documents from the search results; the abstracting service module refers documents with requested information to a report. The *POSHUK* search engine operates both as an independent information retrieval system (back end) and as information processing module (front end)

### IPR Protection

IPR2

### Stage of Development. Suggestions for Commercialization

IRL6, TRL6  
Client-server software  
is ready for installation upon request

### Contact Information

*Ksenia K. Duchnovska*, International Research and Training Center for Information Technologies and Systems of the NAS of Ukraine and the Ministry of Education and Science of Ukraine;  
+38 067 194 74 86, e-mail: [duchnov@ukr.net](mailto:duchnov@ukr.net)

## REFERATOR+ AUTOMATIC TEXT REVIEWING SYSTEM



### Areas of Application

The system is designed to create abstracts of electronic text documents for end users. It is aimed at news agencies and analytic centers processing information from open sources

### Specification

The system is implemented on text editor interface. It provides topic spotting, performs basic terminology analysis, and selects thematic elements from text for abstract compilation. The duplicate detection function enables to compile multi-document abstracts (to create a summary from several sources). The system keeps an internal database of documents. Requirements: Windows XP operating system or higher

### Advantages

As compared with other systems, *Referator+* is designed to work with English, Ukrainian, and Russian languages. The combination of terminology analysis, topic spotting, duplicate detection, and text editor enables quick and convenient use

### IPR Protection

IPR1, IPR3

### Stage of Development.

#### Suggestions for Commercialization

IRL3, TRL5

Customization to types of texts and requirements of end users, upon request

### Contact Information

*Volodymyr Y. Taranukha*, International Research and Training Center for Information Technologies and Systems of the NAS of Ukraine and the Ministry of Education and Science of Ukraine; +38 044 502 63 19, e-mail: dep165@irtc.org.ua

## SemSearch ADVANCED SEARCH SYSTEM



### Areas of Application

The system is designed to improve search by expanding and refining the keyword set. It is aimed at news agencies and think tanks having their own document databases and making their analysis

### Specification

For a given short set of keywords an expanded list of keywords is produced and offered as suggestion to user in order to expand and to refine the search query. The system is implemented as an add-on for conventional search engines such as Google. Also it is implementable for other systems. Requirements: Windows XP operating system or higher

### IPR Protection

IPR1, IPR3

### Advantages

In comparison with other systems SemSearch does not focus on stable combinations that occur in user search queries. The system takes additional information from UkrWordNet using semantic similarity measures. This is especially useful when the base where search is performed is closed or private and has insufficient number of users or amount of search queries to make keyword collocations and feedback on search results statistically significant

### Stage of Development. Suggestions for Commercialization

IRL3, TRL5  
Customized upon request

### Contact Information

Vladimir Y. Taranukha, International Research and Training Center of Information Technologies and Systems of the NAS of Ukraine and the Ministry of Education and Science of Ukraine; +38 044 502 63 19, e-mail: dep165@irtc.org.ua

## SimEnPhysiol SOFTWARE APPLICATION

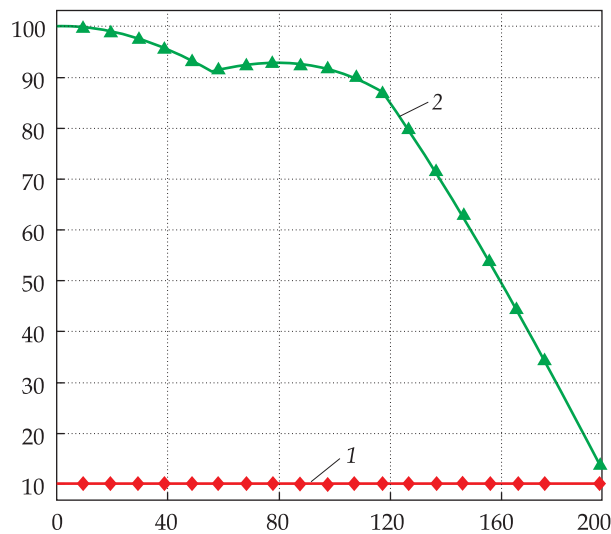

Simulation of insulin-glucose model: insulin (1) and glucose (2) dynamics

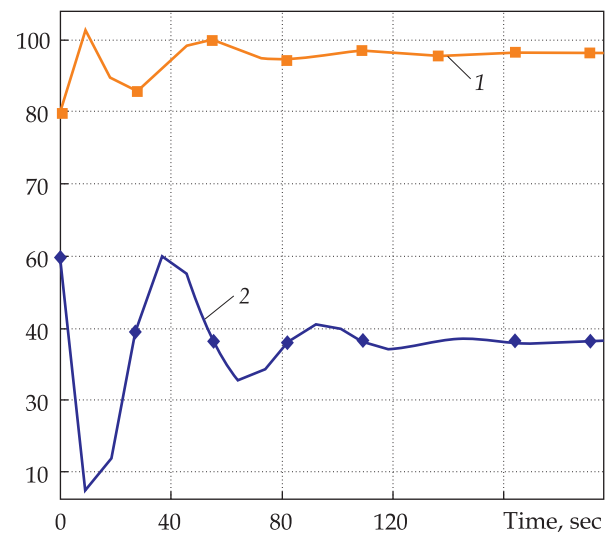

Simulations of cardiovascular model: mean arterial pressure (1) and heart rate (2) dynamics

### Areas of Application

The software is to be used for simulating the processes that occur in the human body in response to temporary or chronic lack of energy (ATP molecules) in the cells. It allows the user to build a scheme of computer simulation, to implement it, to build graphs of selected physiological characteristics, and to analyze the cause-and-effect relationship. The software can be used by the physiologists to deeper understand the principles of physiological supersystem operation and to find adequate methods for researching such systems, as well as by the students of medical establishments to comprehensively study physiology

### Specification

*SimEnPhysiol* is the first ever application software tool that combines the energy producing mechanisms at the cellular level with the mechanisms supporting the aerobic ATP synthesis in the whole organism

### Advantages

*SimEnPhysiol* has no counterparts

Stage of Development.  
Suggestions for Commercialization

IRL6, TRL4  
Customization upon request

IPR Protection

IPR1

### Contact Information

Gregory B. Moroz, Institute of Software Systems of the NAS of Ukraine;  
+38 044 526 33 09, e-mail: mgb@isofts.kiev.ua

# SOFTWARE FOR CALCULATING THE DYNAMIC AND ENERGETIC CHARACTERISTICS OF THE HUMAN GAIT WITH BELOW-KNEE PROSTHESIS

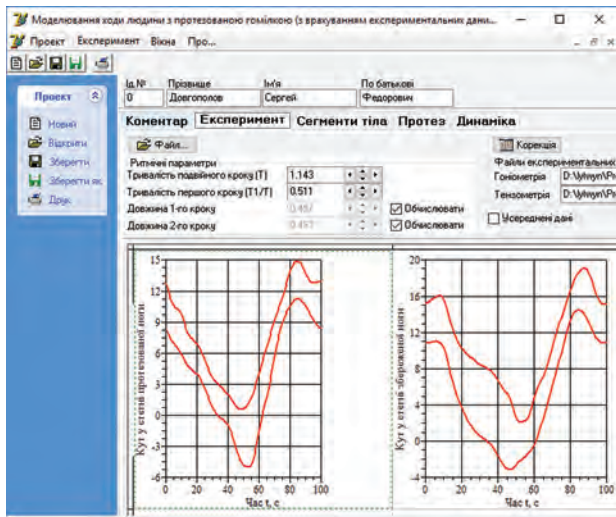

Input of biomechanical measurement data

## Areas of Application

The software is designed for calculating dynamic and energetic characteristics of the human gait with below-knee prosthesis based on the data of biomechanical (goniometric, podographic, and tensometric) measurements

## Specification

The software is a modern Windows application with multi-window interface suitable for inputting data, calculating the human gait characteristics, saving data (datasheets, charts), and printing. The software is based on mathematical model of the human gait with below-knee prosthesis developed by authors and optimal energetic approach to calculating the gait characteristic with incomplete set of initial data

Stage of Development.  
Suggestions for Commercialization

IRL3, TRL3  
Supply, customization, support,  
and staff training, upon request

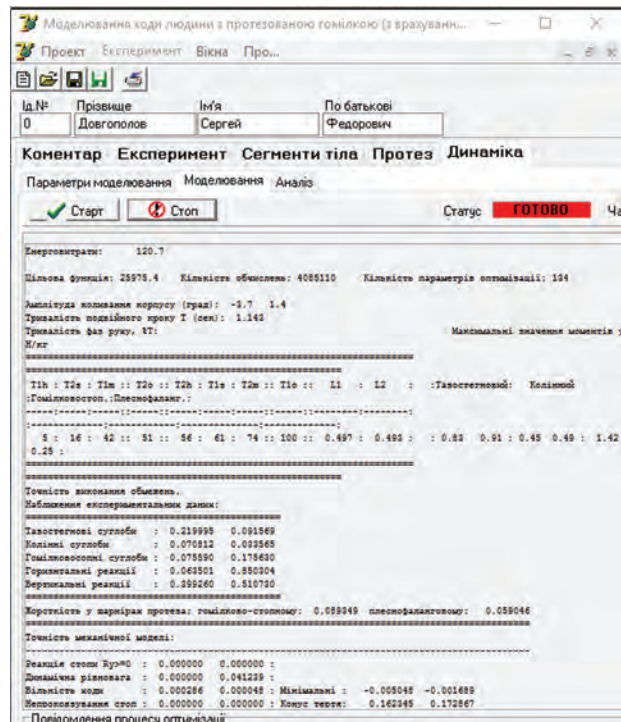

Human gait parameter calculation results

## Advantages

There are no domestic analogs of software. In comparison with foreign counterparts the proposed software has a much lower commercial cost, is based on simpler models of the human gait, and takes into account full natural sequence of feet movement, kinematic and dynamic restrictions within double step interval, and prosthesis stiffness

## IPR Protection

IPR2

## Contact Information

Myroslav V. Demydyuk, Pidstryhach Institute for Applied Problems of Mechanics and Mathematics of the NAS of Ukraine; +38 098 953 19 72, e-mail: m\_demydyuk@ukr.net

# SYMBOLIC SIMULATION TECHNOLOGY FOR TESTING AND VERIFYING HIGHLY-RELIABLE SOFTWARE SYSTEMS

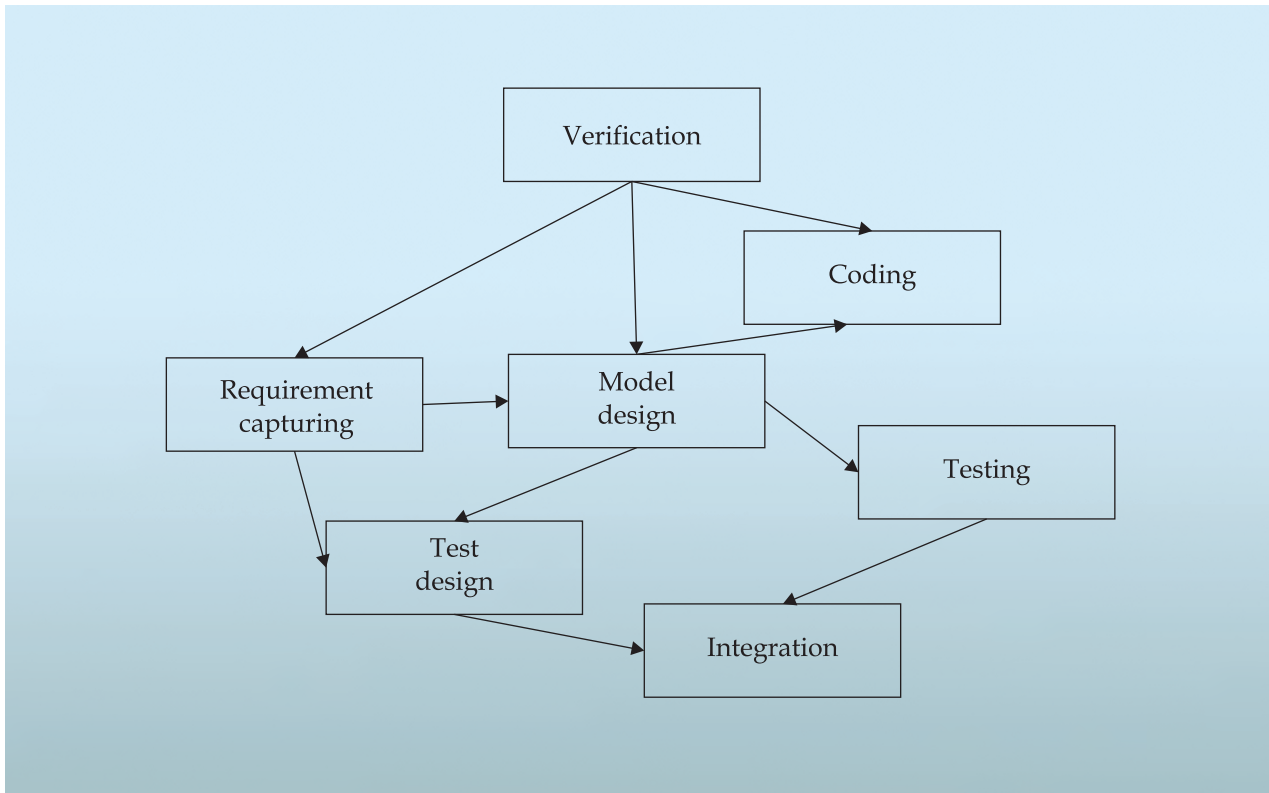

## Areas of Application

The technology is aimed at designers of software for safety-critical systems in aviation, military, telecommunication, and medicine areas

## Specification

The technology reaches 100% test coverage of the code and analyzes 100% states of the system

## IPR Protection

IPR1, IPR3

## Advantages

There are no counterparts in the world in terms of the use of symbolic computations for software development

## Stage of Development. Suggestions for Commercialization

IRL6, TRL4  
Commercial versions of software system and staff training, upon request

## Contact Information

*Sergii V. Yershov*, Glushkov Institute of Cybernetics of the NAS of Ukraine;  
+38 044 526 41 78, e-mail: ErshovSV@nas.gov.ua

# TARAS SHEVCHENKO SCHOLARLY RESEARCH AND EDUCATIONAL PORTAL

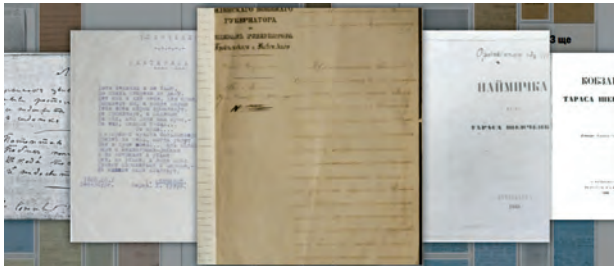

Provision of original texts

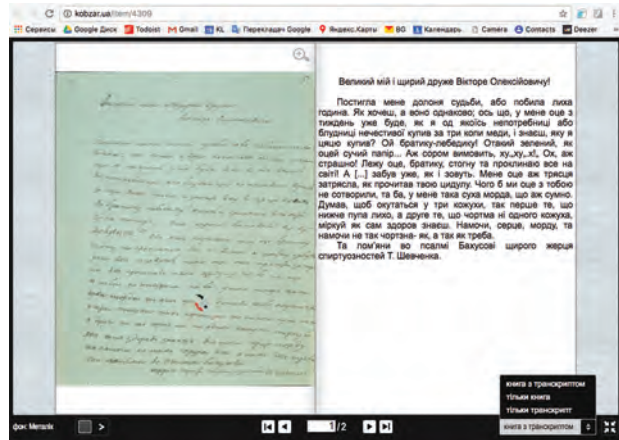

Handwritten text processing

## Areas of Application

The scholarly research and educational portal is created to provide information on Taras Shevchenko as personality, artist, poet, and philosopher; on conditions for the emergence, existence, and development of his genius and his influence on the essential milestones of social development. The portal allows users to study the life journey and works of Taras Shevchenko, his impact on the entourage and historical events in the past, the present, and the future

## Specification

A portal solution of virtual laboratory for collective learning of thematic knowledge has been developed. The solution is implemented as server software with a web access, which can be integrated into scholarly research and educational portals

## IPR Protection

IPR2

## Advantages

The portal is the world largest database of knowledge about Taras Shevchenko and all aspects of his life and creativity. It has a unique and exclusive content combined with advanced interactive web services. The product has no counterparts

## Stage of Development.

### Suggestions for Commercialization

IRL6, TRL9

Free access to the portal at <http://kobzar.ua>

## Contact Information

Kyrylo D. Guliaiev, Institute of Telecommunications and Global Information Space of the NAS of Ukraine; +38 067 502 12 78, e-mail: [k.guliaiev@gmail.com](mailto:k.guliaiev@gmail.com)

## TECHNOLOGY FOR MASSIVE LIFELONG ELECTRONIC LEARNING SUPPORT

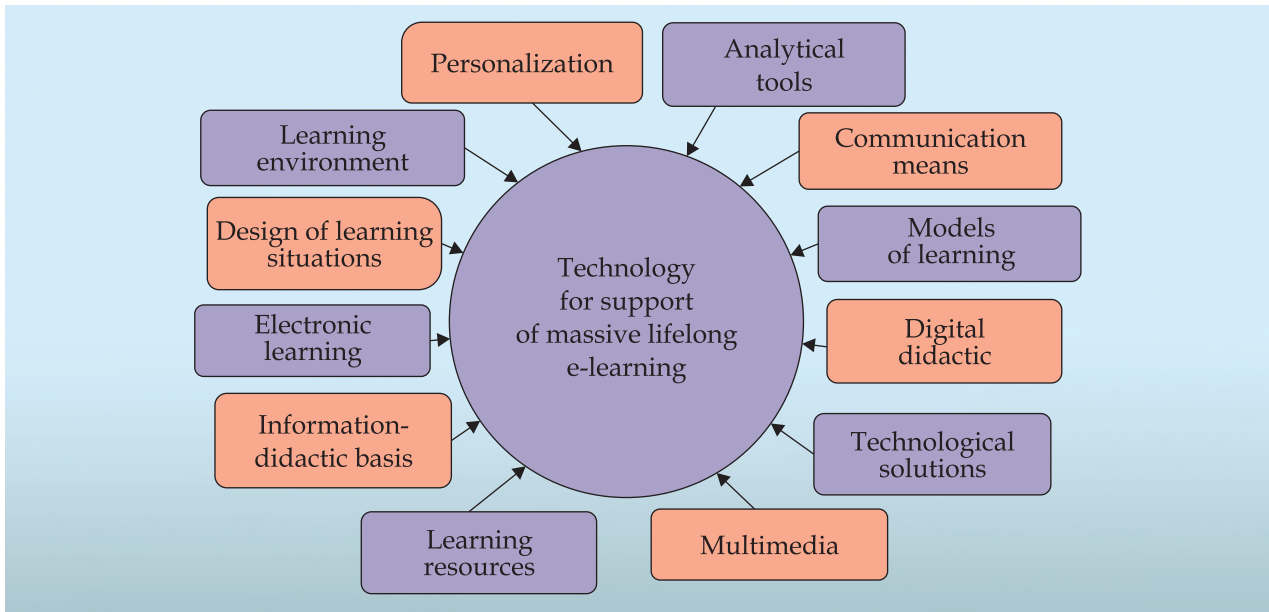

### Areas of Application

Development of e-learning resources for lifelong learning

### Specification

The technology is based on the use of Internet. Design and development of e-learning resources meets the psycho-educational, technical, technological, aesthetic, functional, and ergonomic requirements

### Stage of Development. Suggestions for Commercialization

IRL2, TRL2  
Access to online resource and staff training, upon request

### IPR Protection

IPR1, IPR2

### Advantages

No counterparts have been known so far. The technology aims at intensive development and implementation of e-learning using advanced models based on the active use of digital didactic techniques in the interactive learning environment, supports communications among the participants of the learning process with the effect of the presence of students and teachers, and enables a variety of electronic consultations. The technology allows for organizing a balanced massive lifelong learning, creating a necessary information-didactic framework, accumulating desired e-learning content and resources, as well as for creating an effect of learning intensification and individualization. The use of analytical tools ensures customizing e-learning and reaching multiple goals by means of massive lifelong learning

### Contact Information

Alla F. Manako, International Research and Training Center for Information Technologies and Systems of the NAS of Ukraine and the Ministry of Education and Science of Ukraine; +38 044 502 63 51, e-mail: alla@irtc.org.ua



## TECHNOLOGY FOR PERSON IDENTIFICATION BY FACIAL IMAGE

### Areas of Application

The technology is to be used in access control systems of premises, computers, etc., in criminalistics, border control, and biometric identification systems, as well as for the search of person's images in databases and networks

### Specification

The technology has been tested on international facial images databases and has proved itself to be as reliable as the best known analogs

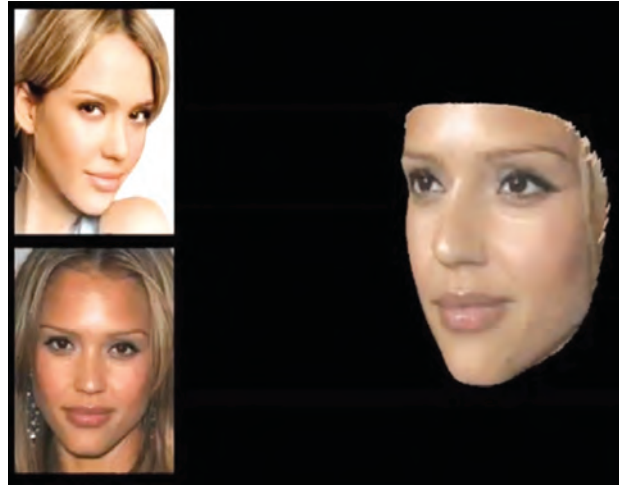

### Advantages

Due to the use of original method for reconstruction of 3D human face model by series of images, this technology shows a high reliability of recognition without expensive equipment like laser range meters or special lightning involved

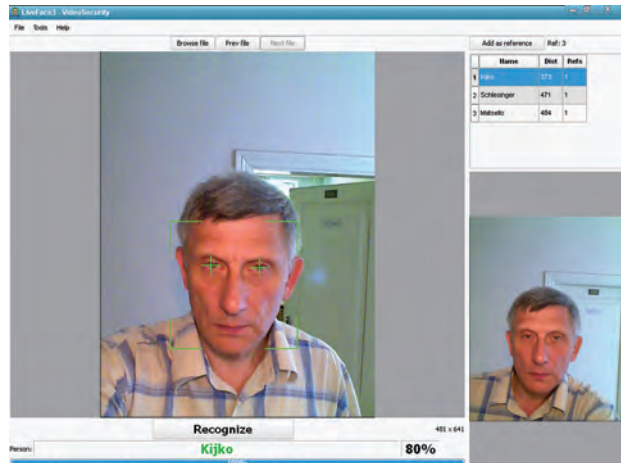

Example of personal identification by facial image

### Stage of Development. Suggestions for Commercialization

IRL8, TRL7  
Software installation, maintenance,  
and staff training, upon request

### IPR Protection

IPR3

### Contact Information

*Viacheslav V. Matsello*, International Research and Training Center for Information Technologies and Systems of the NAS of Ukraine and the Ministry of Education and Science of Ukraine;  
+38 044 526 30 18, e-mail: matsello@gmail.com

## UKRAINIAN NATIONAL LINGUISTIC CORPUS LEXICOGRAPHICAL SYSTEM

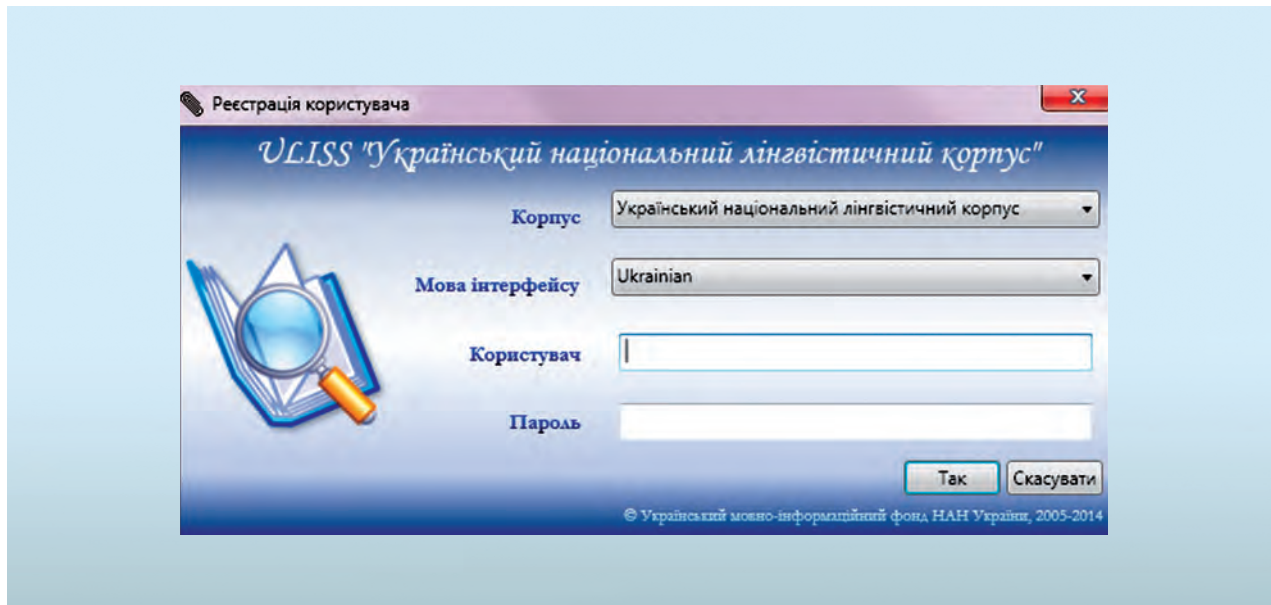

User's interface of Ukrainian National Linguistic Corpus Lexicographical System

### Areas of Application

This lexicographical system is designed for creating text corpuses in Ukrainian and for studying language phenomena and cognitive-communicative structures. It is aimed at the linguists, lexicographers, philology students, and those who studies linguistic phenomena

### Advantages

This virtualized distributed information system for creating, studying, and developing the text corpuses has no analogs in Ukraine. It is re-designable for any language and has advanced software tools for common distributed lexicographical work with the usage of information technologies of virtualization, service-oriented architecture, and theory and technology of lexicographical systems

### Specification

The system requirements for the frond-end and the back-end components:  
OS Windows XP SP3 or higher

### Stage of Development. Suggestions for Commercialization

IRL5, TRL6  
Free trial version is available via Internet.  
Full-featured system is developed on paid basis.  
Customized redesign, including redesign for other languages, is possible

### IPR Protection

IPR2

### Contact Information

Volodymyr A. Shyrovov, Ukrainian Lingua-Information Fund of the NAS of Ukraine;  
+38 044 525 86 75, e-mail: vshirokov48@gmail.com

# UKRAINIAN-RUSSIAN-ENGLISH DICTIONARY OF WELDING TERMINOLOGY VIRTUAL LEXICOGRAPHICAL LABORATORY

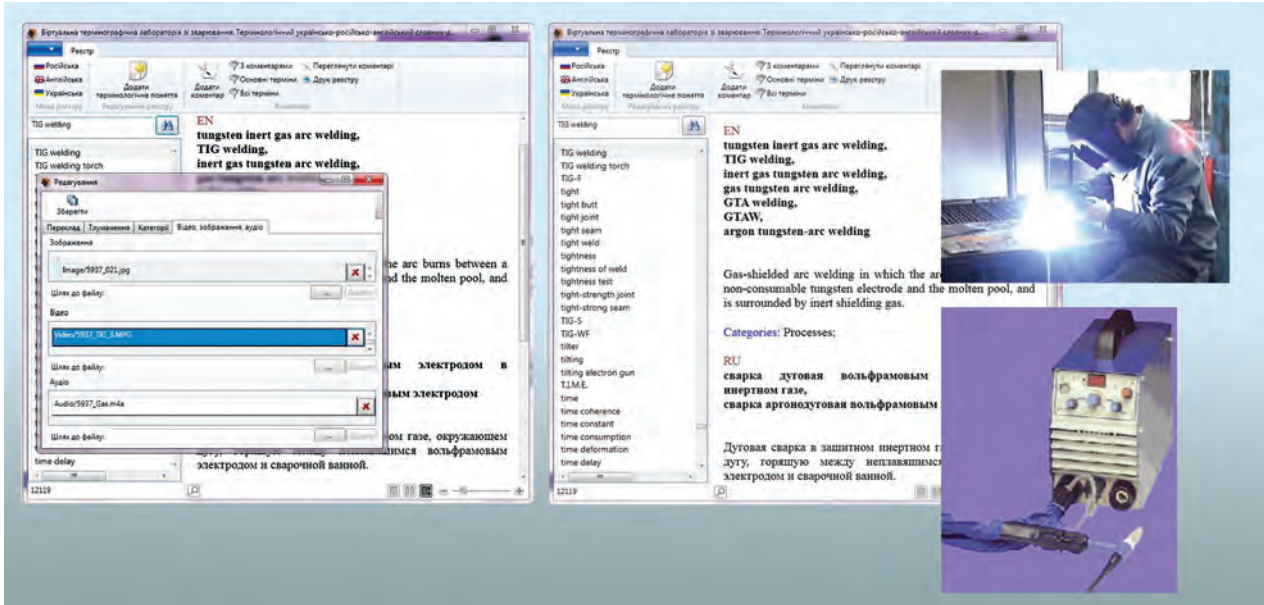

Ukrainian-Russian-English Dictionary of Welding Terminology Virtual Lexicographical Laboratory. Editing and review of multimedia elements of terminological blocks

## Areas of Application

This product is designed to supporting the process of creating the Ukrainian Dictionary of Welding Terminology by geographically distributed group of lexicographers and experts in virtual mode. It is aimed at the linguists and other professionals in the field of welding

## Advantages

This new system for creating and developing the terminological multilingual dictionaries has no analogs in the world. The system can be redesigned for whatever languages. It has advanced software tools for common distributed lexicographical work with the usage of virtualization information technologies, theory and technology of service-oriented architecture and lexicographical systems

## Specification

The system requirements for the frond-end and the back-end components:  
OS Windows XP SP3 or higher

## Stage of Development. Suggestions for Commercialization

IRL5, TRL6  
Free trial version is available via Internet. Full-featured system is developed on paid basis. There is an option of customized redesign, including redesign for other languages

## IPR Protection

IPR2

## Contact Information

Volodymyr A. Shyrokov, Ukrainian Lingua-Information Fund of the NAS of Ukraine;  
+38 044 525 86 75, e-mail: vshirokov48@gmail.com

## WebSten SYSTEM FOR SPONTANEOUS SPEECH TO TEXT CONVERSION



здавалося що з цього має логічно витікати що вона цьому сказав насправді не хотілося бути раз не масово вони кажє для того щоб не створювати і чинник можна коментувати цю політичну силу по здається логічним її культурно як січ на і якась т якою треба бути сатурну вихід незрозуміло з я третій нової моп один ця іншим кроком тому послідовність і принаймні він володимир є абс створення нової яка зате викликає те в чому раз такє ж как можеє називається так це не щось а як кані центра за діставатися такий а варіанти її спа що складів не чули щоб назвати радикальну додатковим талоном чи вам як тимка знову не ство з точки зору політологічна академічного підходу вибори ця коаліції не працюю не прати це важко уряду які разом стрім пішов поки що в відставку у законодавчого органу було би як на мене луйш т важко й вйти я сподіваюся що буде сформований щоб якось вирішити поточні питання давайте фрак

Search results for a set of keywords specified as *академі\** that covers the words “academy”, “academic”, and “academician” in different cases. Normally, most of found broadcast episodes are relevant to your search. You can click a highlighted word to check the episode relevance and to analyze the spotted information

### Areas of Application

Web system for speech-to-text conversion of audio and video files loaded from user PC or from the Internet

### Specification

Languages: Ukrainian, English, and Russian (expansion is possible); word accuracy is 60–90% (depending on the record quality); information width of the primary audio stream: at least, 60 kbit/s

### Advantages

Foreign analogs exist for other languages; speaker diarization; search of fragments by text, speaker, etc.; control of recognition speed depending on priority; text view synchronized with media content and vice versa; editing of the recognition results to obtain verified transcripts

### Stage of Development. Suggestions for Commercialization

IRL3, TRL5  
Potential users: TV and radio studios, think tanks, intelligence services.  
Customizable upon request

### IPR Protection

IPR1, IPR2

### Contact Information

Mykola M. Sazhok, International Research and Training Center for Information Technologies and Systems of the NAS of Ukraine and the Ministry of Education and Science of Ukraine; +38 044 502 63 33, +38 067 235 29 76, e-mail: sazhok@gmail.com

## TECHNOLOGY READINESS LEVEL (TRL) SCALE

| Stage                              | TRL  | Interpretation   | Definition and Description   |
|------------------------------------|------|--|--|
| Invention                          | TRL1 | Basic principles observed                                  | Basic scholarly research is translated into potential new basic principles that can be used in new technologies  |
|                                    | TRL2 | Technology concept formulated                              | Potential areas of application of basic (technological) principles, including the technological concept are identified. Basic manufacturing principles are elaborated and potential sales markets are identified. A small research team is established to assess the project feasibility   |
| Concept validation                 | TRL3 | First assessment of concept and technology effectiveness   | Based on preliminary study, actual research is conducted to assess technical and market feasibility of the concept. This includes active R&D works at the lab and first negotiations with potential customers. The research team expands. Market feasibility is assessed   |
|                                    | TRL4 | Prototype validation at lab                                | Basic technological components are integrated to assess early feasibility by testing in laboratory environment. Manufacture options are studied with basic manufacturing principles identified. Key markets are researched to study demand. The organization is ready to scale up, possible services are analyzed. Comprehensive marketing analysis is made  |
| Prototyping and incubation         | TRL5 | Prototype testing in user environment                      | The system is tested in user environment with broader technological infrastructure involved. The actual use is tested and validated. Production-support works and pre-production tests are done in lab environment. Trial batches of prototypes enter the key markets. The organization starts activities to further distribute the prototypes and to enter the sales markets  |
| Pilot production and demonstration | TRL6 | Pre-production, including tests in user environment        | The product and manufacturing technologies are completely ready for launch of a pilot line/pilot plant (low-scale manufacture). The product and manufacturing technologies are assessed and finalized. This may include additional R&D works. The early products and manufacturing technologies are tested in the key markets with simultaneous organization of manufacture (marketing research, logistics, production facilities, etc.) |
|                                    | TRL7 | Low-scale pilot production demonstrated                    | The product manufacture is fully operational at low rate. Actual commercial products are manufactured. The final products are verified in the key markets. The organizational component is completed (comprehensive marketing strategy, all components of manufacturing activities). The products are formally launched in test markets  |
| Initial market introduction        | TRL8 | Manufacture fully tested, validated, and certified         | The manufacturing flow charts, product final version, production organization, and marketing tools are completed. The full-scale manufacture has been launched. The final product is sold in majority of domestic and international markets  |
| Market expansion                   | TRL9 | Manufacture and products fully operational and competitive | The full-scale manufacture is sustainable, with the product gaining new markets. Minor modifications and improvements create new versions. The technology and product output are optimized through implementing innovative concepts on manufacturing process. The product is fully customized to the key markets   |

## INNOVATION READINESS LEVEL (IRL) SCALE

| IRL  | Innovation Readiness Level   | Definition   |
|------|--|--|
| IRL1 | Inventor or team with a dream  | The lowest level of readiness where the intention transforms into an idea of space system application or the space technology transforms into a business venture   |
| IRL2 | Paper studies produced   | Once the basic ideas have been formulated, they are put down on paper in studies and analyses of business opportunities  |
| IRL3 | Experimental evidence of business opportunity  | Active research and development are initiated, including analytical / laboratory studies to validate predictions regarding the market, the competition, and the technology   |
| IRL4 | Capability to implement limited-scope programs with project teams                                      | Basic technological and business components have been developed to establish that they will work together; an initial business plan is available   |
| IRL5 | Capability to support project engineering development and design (no product, no revenues)             | The basic technological and business components have been integrated with reasonably realistic supporting elements. The business plan is credible, but still needs to be validated against the final product characteristics   |
| IRL6 | Capability to support development and design with a market-driven business team (product, no revenues) | The representative prototype system has been tested in a relevant environment. The business team is still incomplete and the venture is not yet ready for commercialization. A full business plan including the market, the operational, the technological, and the financial aspects is available |
| IRL7 | Capability to support limited production; full business team in place (product and limited revenues)   | The business can run on a limited scale. The full team is in place   |
| IRL8 | Capability to advance to full production and distribution (product and revenues)                       | The technology has been proven to work and the venture structure has proven to be able to support growing market shares  |
| IRL9 | Fully articulated business with appropriate infrastructure and staffing (growing market share)         | The offering incorporating the new technology has been used in operational conditions and the business is running with a growing market share  |

## Intellectual Property Rights Protection<sup>1</sup> Levels

| IPR codes | Protection Level  |
|-----------|---|
| IPR1      | Technical solutions are know-how <sup>2</sup>   |
| IPR2      | Applications for copyright protection of IPR objects are expected to be or have been submitted  |
| IPR3      | The copyright protection of IPR objects as established by the applicable law of Ukraine has been obtained and is kept in force  |
| IPR4      | International industrial patent application(s) (according to the PCT system, etc.) has (have) been submitted.<br>Application(s) for industrial patents has (have) been submitted in foreign country(ies) under national procedure |
| IPR5      | The industrial patent(s) in foreign country(ies) has (have) been obtained and is/are kept in force  |

<sup>1</sup> The IPR protection measures are implemented by R&D institutions in accordance with the applicable legislation of Ukraine and the requirements of paragraphs 5, 8, and 9 of the Regulations for the use of intellectual property objects at the NAS of Ukraine as approved by Resolution of the Presidium of the NAS of Ukraine No.15 of January 16, 2008, on the Structural Units Responsible for Technology Transfer, Innovation Activities, and Intellectual Property (as revised)

<sup>2</sup> Know-how is technical, organizational, or commercial data obtained with the use of experience and upon trials of technology and its components, which are: closely held (not a part of general knowledge or available for public) on the date of license agreement; essential, i.e. important and useful for manufacture of products, manufacturing process, and/or provision of services; and elaborate i.e. detailed and complicated enough to verify their compliance with the criteria of being never-before-known and essential (Clause 1 of the Law of Ukraine on the State Regulation of Technology Transfer Activities)

Reference book

THE NATIONAL ACADEMY OF SCIENCES OF UKRAINE

**R&D  
AND TECHNOLOGIES**

**THE NAS OF UKRAINE**

IN 11 SPECIAL ISSUES

Issue

INFORMATION TECHNOLOGY

Compiled by  
I.A. Malchevskyi and S.A. Bepalov

Translated, edited, and proofread  
by O.A. Zagorodnia

Art work by  
Ye.O. Ilnytskyi

Technical editor  
T.M. Shenderovych

Desktop publishing by  
V.M. Kanishcheva, N.M. Kovalenko,  
and S.V. Kubariev

Illustrative materials prepared by  
N.M. Kovalenko

Signed to print 18.05.2018.  
Format 60 × 84/8. Font: Book Antiqua.  
Conventional printed sheets 5.23. Published sheets: 4.14.  
Circulation 100 copies. Order № 5270.